

SIB416 Sensor Interface Board Hamamatsu S11064 MPPC

Product Sheet

Description

The SIB416 sensor interface board allows up to four Hamamatsu S11064 multi-pixel photon counter (MPPC) devices to easily interface to a Vertilon PhotoniQ multichannel data acquisition system. The devices are inserted into receptacle pins where their cathode output signals are routed to connectors that connect the device outputs to the PhotoniQ. Bias to MPPC arrays is provided on a high voltage cable by the PhotoniQ where it can be enabled and configured through the PhotoniQ graphical user interface. A special current-sense output from the bias interface circuitry is sent to a variable gain preamplifier to represent the total charge signal measured by all four MPPC arrays. This signal is fed into a user-programmable threshold leading edge discriminator that generates a trigger signal when an event exceeding a particular energy threshold is detected on any of the S11064 devices. The trigger output is typically connected to the trigger input on the PhotoniQ data acquisition system. Alternatively, the trigger output can be sent to other external hardware that could perform coincidence detection or precise time-to-digital conversion. The full functionality and operation of the SIB416 is conveniently controlled through the PhotoniQ's graphical user interface.

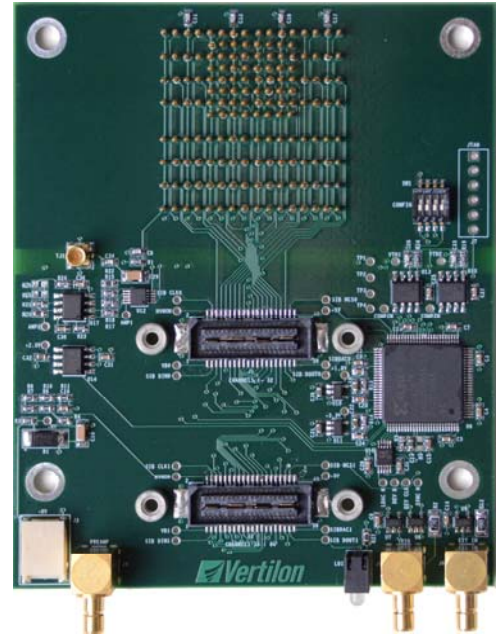

Typical Setup

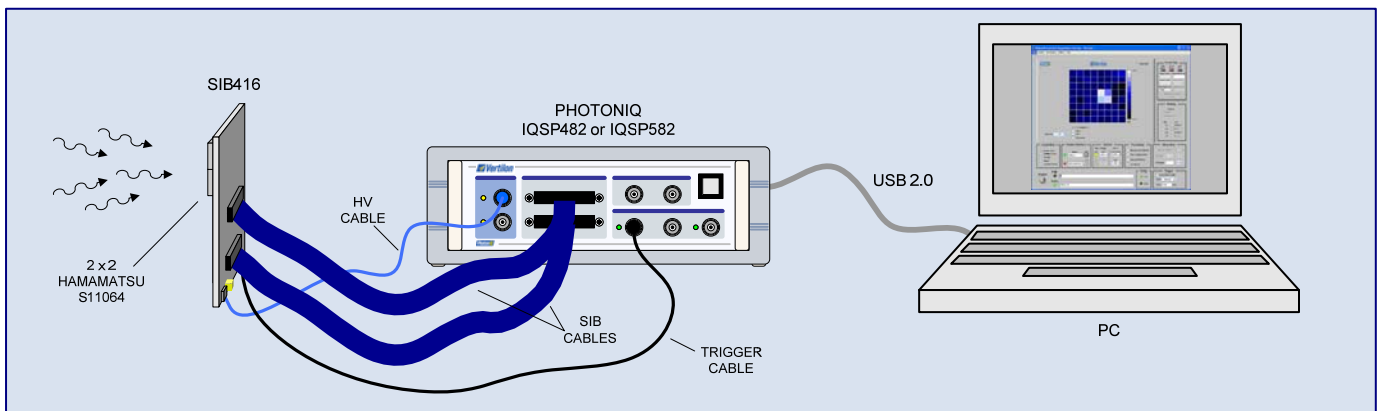

Four Hamamatsu S11064 MPPCs in a 2 x 2 arrangement are attached to the SIB416 which is positioned in an optical assembly to detect incoming radiation. The 64 cathode outputs from the MPPC arrays are routed on the SIB416 to the SIB connectors that connect to a PhotoniQ IQSP482 or IQSP582 multichannel data acquisition system. The discriminator channel produces a trigger to the PhotoniQ whenever a radiation event is detected on any of the MPPCs. The energy level threshold for the radiation event is set by the user through the PhotoniQ graphical user interface. Charge signals from the 64 cathodes of the S11064 devices are acquired by the PhotoniQ for each trigger produced by the SIB416. Digitized output data from the PhotoniQ is sent through a USB 2.0 connection to a PC for display, logging, or real time processing. In the figure below, the PhotoniQ GUI is set to display an 8 x 8 image of the energy levels for each event captured.

Functional Block Diagram

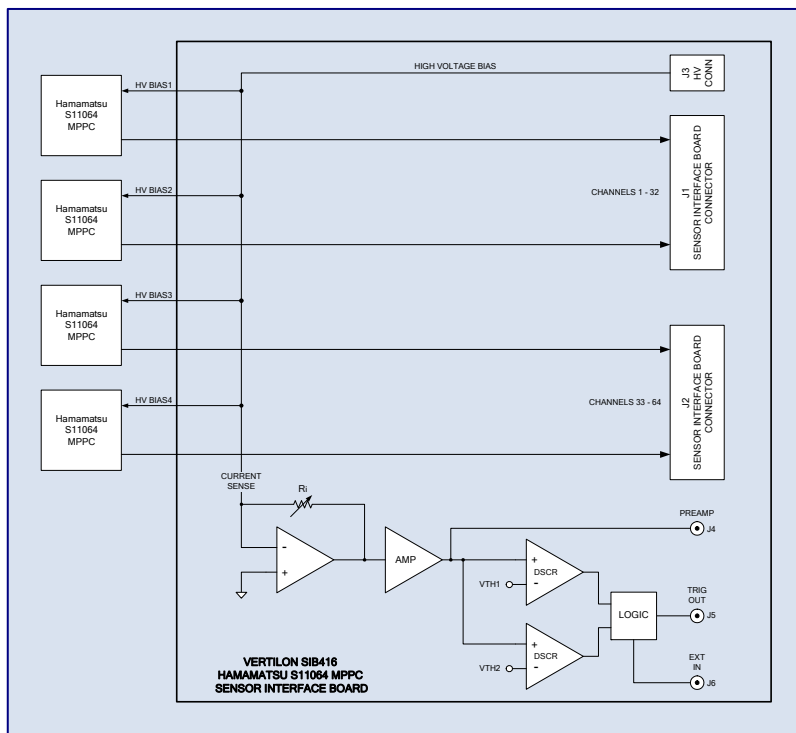

Configuration Dialog Box

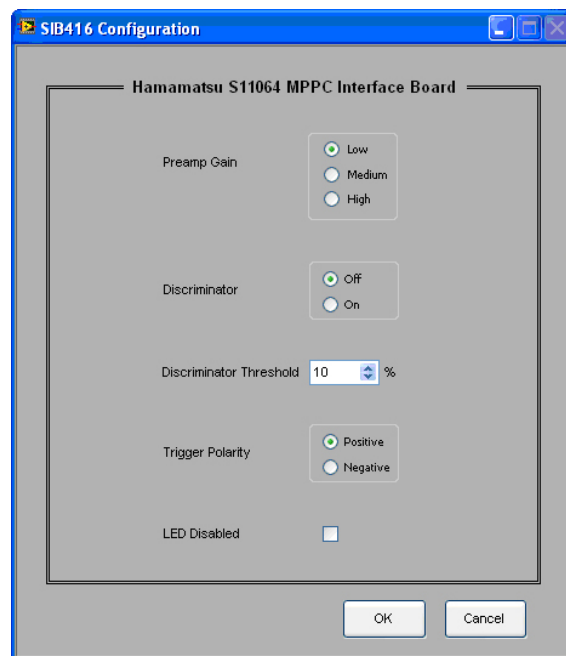

Ordering Information

SIB416 directly compatible with Vertilon PhotoniQ IQSP480 / IQSP580 32 channel and IQSP482 / IQSP582 64 channel data acquisition systems. PhotoniQ systems sold separately. See User Manual for performance specifications.

SIB416 includes two SMB120 coaxial cables, SMB plug to BNC plug, 120 cm.

Sensor interface board (SIB) cables ordered separately. Specify part number SBCxxx, where "xxx" equals length in centimeter.

See SIB416 User Guide for complete specification.

See Hamamatsu S11064 datasheet for specific device information

Mechanical Data

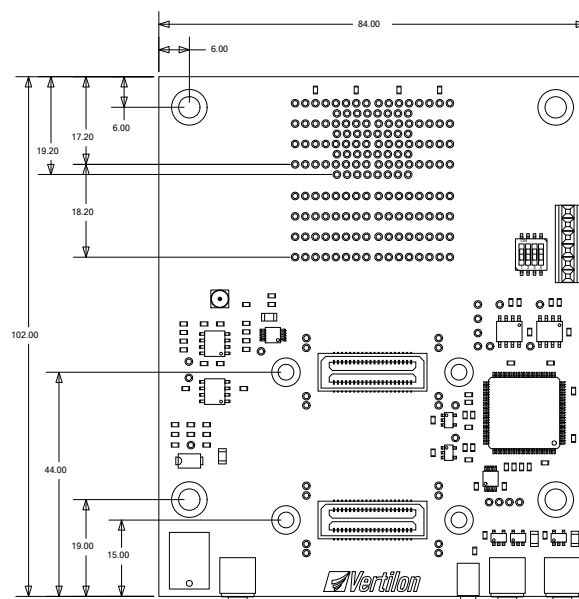

AP Technologies Limited The Coach House Watery Lane Bath BA2 1RL
T: +44 (0) 1225 780 400 F: +44 (0) 8701 266 449 E: info@aptechnologies.co.uk



Vertilon Corporation has made every attempt to ensure that the information in this document is accurate and complete. Vertilon assumes no liability for errors or for any incidental, consequential, indirect, or special damages including, without limitation, loss of use, loss or alteration of data, delays, lost profits or savings, arising from the use of this document or the products which it accompanies. Vertilon reserves the right to change its products without prior notice. No responsibility is assumed by Vertilon for any infringements of patents or other rights of third parties which may result from the use of its products. No license is granted by implication or otherwise under the patent and proprietary information rights of Vertilon Corporation.

© 2011 Vertilon Corporation, ALL RIGHTS RESERVED

PS2724.1.0 Oct 2011

Vertilon Corporation, 66 Tadmuck Road, Westford, MA 01886 / Tel: (978) 692-7070 / Fax: (978) 692-7010 / www.vertilon.com