

Features

- Far ultraviolet LED
- Mercury free
- ESD protection
- Hermetic seal
- Protected by US Patents 9,691,938: 9,871,165: 10,153,395

Applications

- Chemical and biological analysis
- Water quality monitoring
- Gas sensing
- Liquid chromatography

Product overview

The SF1-3T9FWL1 is a powerful, industrial standard metal-can footprint Far UV-C emitting device. A peak wavelength of 237nm LED creates new feasibility for a variety of applications. 237nm LED is effective for Water quality detection of Nitrate (NO₃) Nitrite (NO₂), gas detection of Carbon dioxide (CO₂) and liquid chromatography.

LEDs have an environmental advantage in that they contain no mercury and LEDs are more robust compared to lamps. The Transistor Outline (TO-can) package format, which consists of a header and a cap that together form a hermetically sealed package .

An ESD protection is integrated in industrial standard metal-can footprint.

Table 1. Ordering information

Part Number	Operating Current	Wavelength ¹ (nm)	Radiant Flux ² (mW)	Description
SF1-3T9FWL1-TB	20mA	234~240	> 0.2	Packing in Tray Box

1. Wavelength measurement is @ 20mA forward current, accuracy is ±1.0 nm
2. Radiant flux measurement is @20mA forward current, accuracy is ±10%

Table 2. LED characteristics

Parameter	Symbol	Min	Typ	Max	Units	Test Conditions
Peak wavelength	λ	234	-	240	nm	1, 3
Radiant Flux	P_{OUT}	0.2	-	-	mW	1, 4
Viewing Angle	$2\theta_{50\%}$	-	110	-		1
Spectrum Half Width (FWHM)	$\Delta\lambda$	-	9	-	nm	1, 2
Forward voltage	V	5	-	7	V	1, 5
Thermal resistance junction-case point	R_{TH}	-	10	-	°C/W	1
Power dissipation	P_D	-	0.12	-	W	1

1. $T_{solder\ point} = 25^{\circ}C$ with Peltier controlled heatsink, forward current = 20mA DC
2. Spectrometer measurement with integrating sphere (radiant flux) or tube (radiant intensity)
3. Wavelength measurement accuracy is ± 1.0 nm
4. Radiant flux/intensity measurement accuracy is $\pm 10\%$
5. Forward voltage accuracy is ± 0.2 V

Table 3. Absolute maximum ratings

Parameter	Symbol	Value	Units	Test Conditions
Storage temperature range	T_{STG}	-40 to +100	°C	
Forward current	I_F	50	mA	
Junction temperature	T_J	65	°C	
ESD classification		2		JEDEC # JS-001-2010

6. Driving these UVLEDs from a current source is strongly recommended to avoid overdrive damage. The current flowing in a UVLED is an exponential function of the voltage applied and the use of voltage sources to drive a UVLED is likely to exceed the Absolute Maximum Ratings and lead to damage or failure of the UVLED.
7. Stresses beyond those listed in "Absolute Maximum Ratings" may cause permanent damage to the device. The exposure to the absolute maximum rated conditions may affect device reliability.

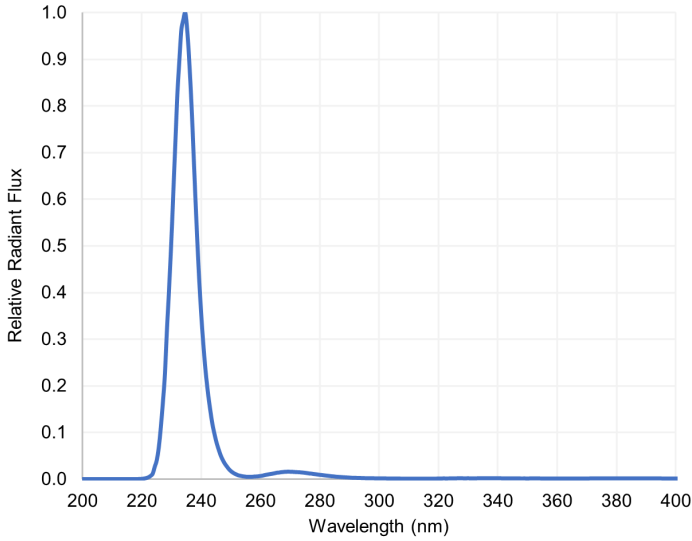

Figure 1. Relative emission intensity vs wavelength
 $T_A=25\text{ }^\circ\text{C}$, $I_F = 20\text{ mA}$

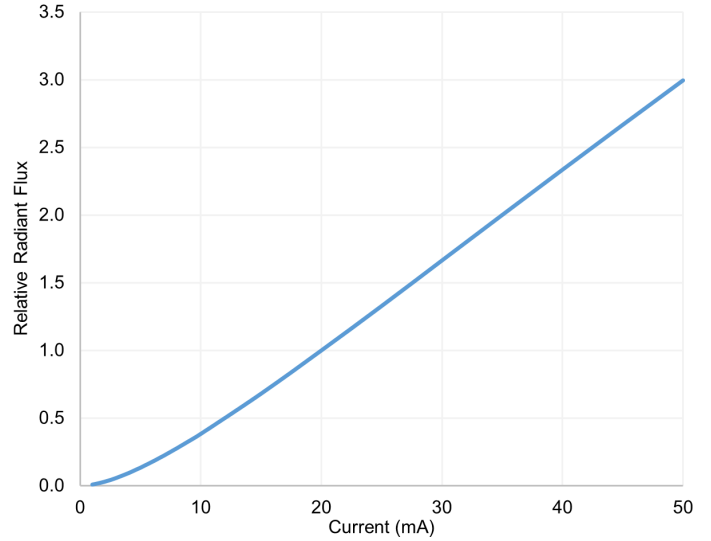

Figure 2. Relative radiant flux vs forward current
 $T_A=25\text{ }^\circ\text{C}$

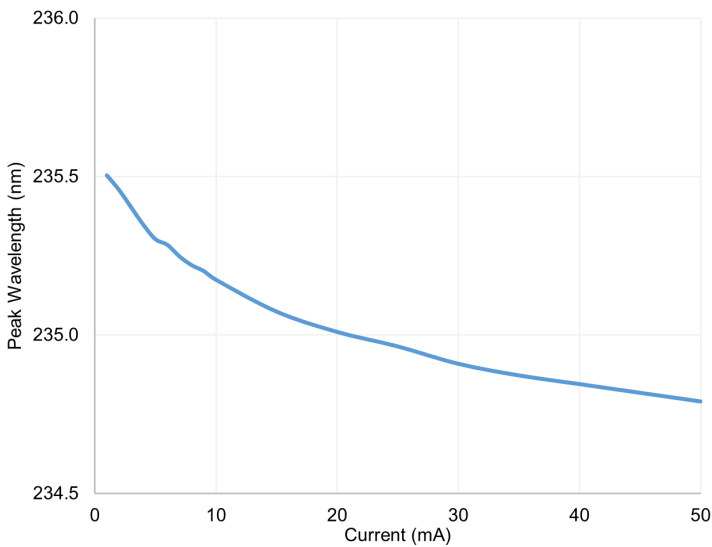

Figure 3. Peak wavelength vs forward current
 $T_A=25\text{ }^\circ\text{C}$

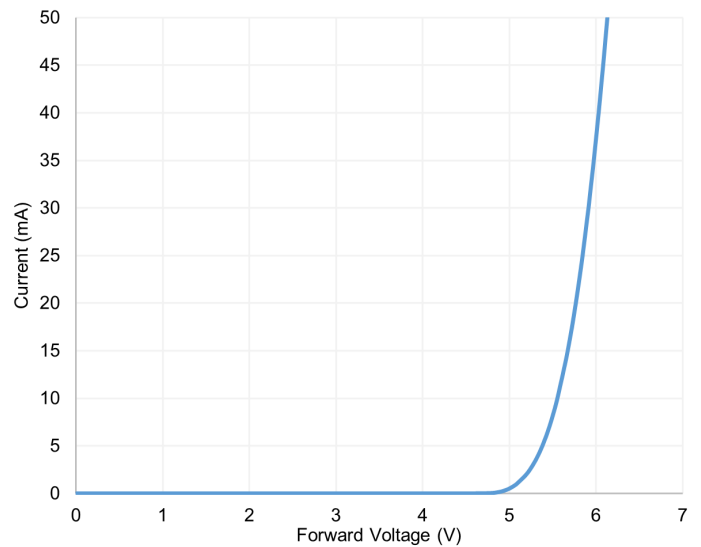

Figure 4. Forward current vs forward voltage
 $T_A=25\text{ }^\circ\text{C}$

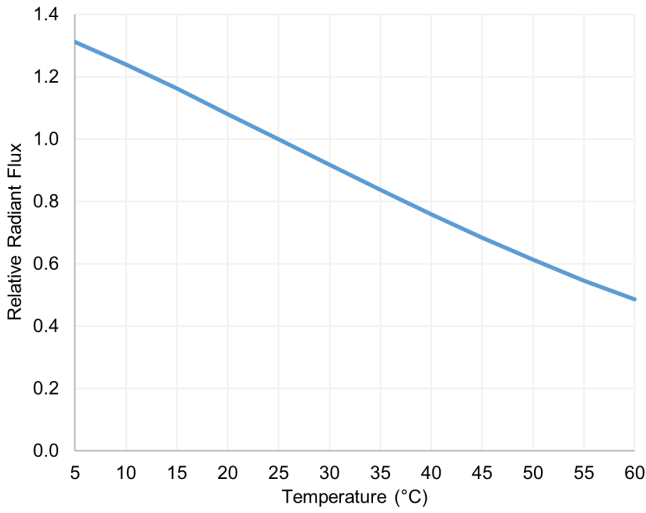

Figure 5. Relative radiant flux vs temperature
 $I_F = 20 \text{ mA}$

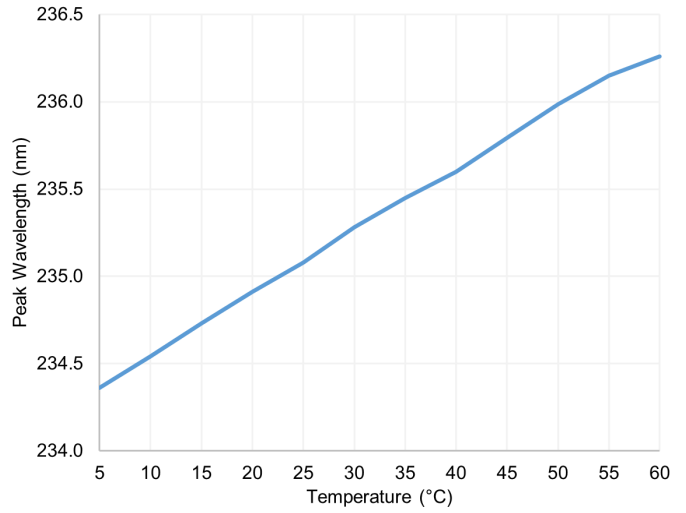

Figure 6. Peak wavelength vs temperature
 $I_F = 20 \text{ mA}$

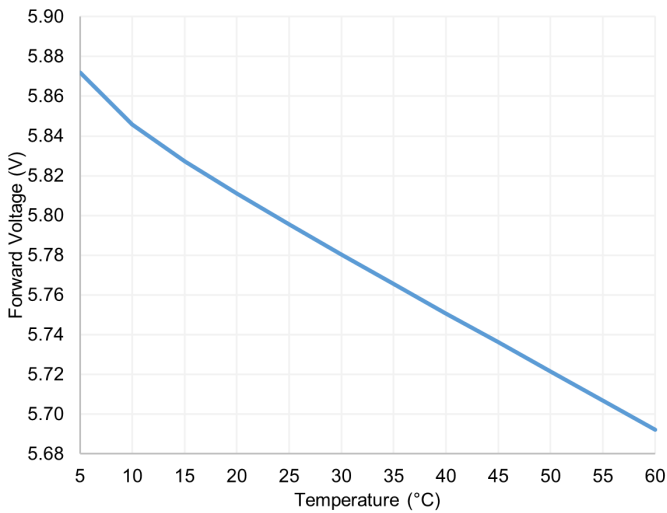

Figure 7. Forward voltage vs temperature
 $I_F = 20 \text{ mA}$

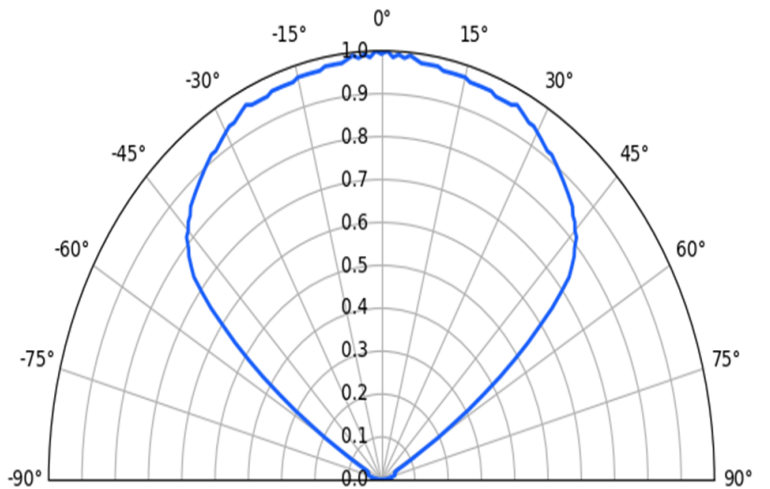
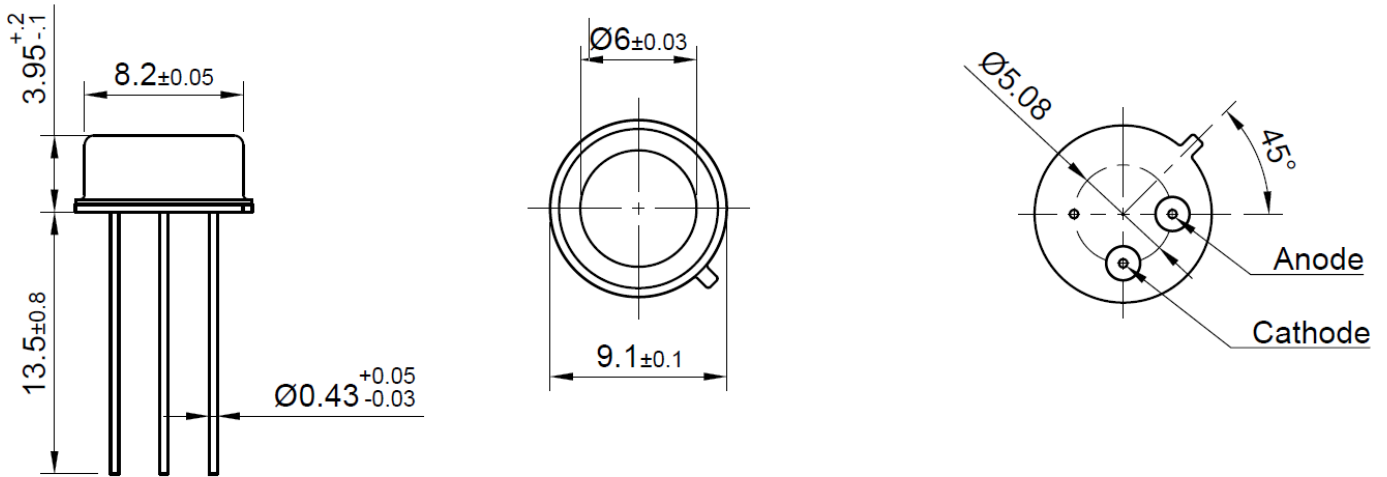

Figure 8. Radiation pattern
 $T_A = 25 \text{ °C}, I_F = 20 \text{ mA}$

Package and layout information



All dimensions in mm

Figure 10. Package dimensions

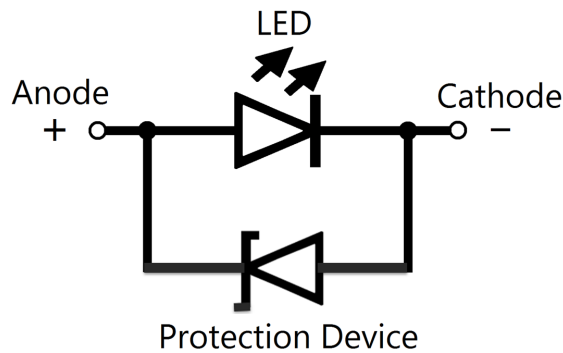

Figure 11. Equivalent circuit

Soldering

Table 4. Soldering conditions

Parameter	Dip Soldering Lead-free solder	Hand Soldering Lead-free solder
Pre-heat	90°C max (backside of PCB)	
Pre-heat time	60 seconds max	
Temperature	260°C max (Solder bath)	300°C max
Soldering time	5 seconds max	3 seconds max

* Distance between melted solder sides to bottom of LED should be 3mm or greater

Soldering Temperature Profile

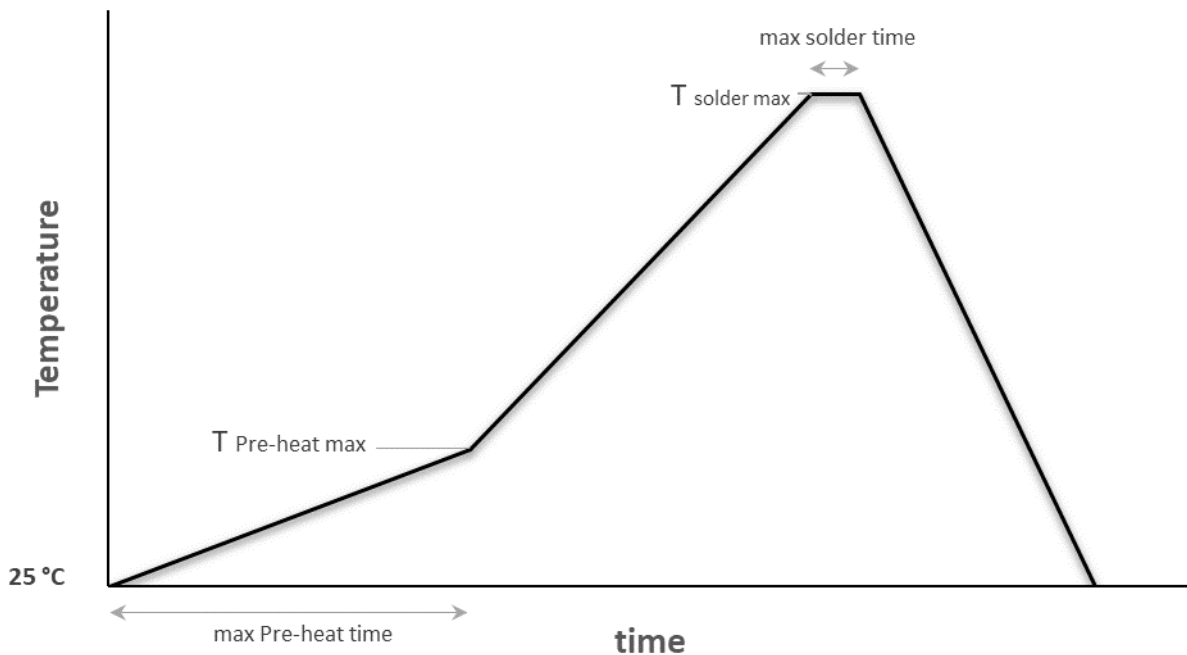

Figure 12. Soldering temperature profile

Recommended usage instructions

Storage

1. Store in a moisture free environment (< 60%RH).
2. Store between 5°C and 30°C.
3. After storing, clean with isopropyl alcohol. Do not use acetone, MKS or ultrasonic baths to clean.

Handling

1. Use ESD tweezers to hold the LED by the sides of the package.
2. Do not touch the optical surface of the LED.
3. Observe appropriate ESD precautions when handling the LED.

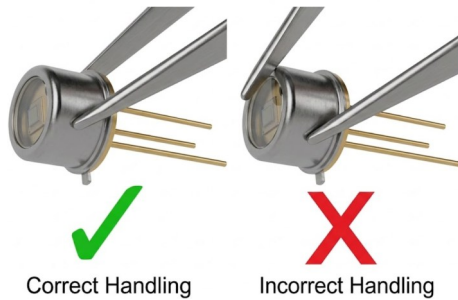

Circuit

1. Driving circuits must be designed to operate the LEDs in forward bias only.
2. A driver IC delivering constant current operation is recommended.
3. The recommended circuit for multiple LEDs involves driving individual load resistances. Each LED can have different forward voltages for the same current.

Safety information

The LED emits invisible UV light during operation. UV light is hazardous to eyes and skin. Long term exposure to UV light increases the risk of skin and eye cancer. Always ensure adequate control measures are in place to prevent exposure to UV light when the LED is operational.

Compliance

RoHS & REACH Compliant.