

# High Power Laser Diode TO-Cans

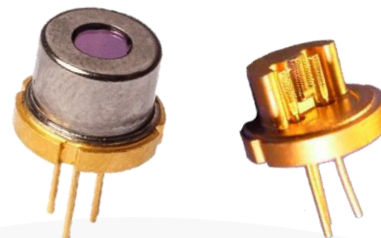

## Part Number: TO9-185

High Power TO9 Package  
Multi-Mode Fabry-Perot  
Pulsed Wavelength at 1360nm  
Lensed Options Available



## Features

- High Output Power
- High Dynamic Range
- High Efficiency
- Standard TO9
- Cost Effective

## Application

- Home Use Medical



SemiNex delivers the highest available power at infrared wavelengths between 12xx and 19xx nm. When necessary, we will further optimize the design of our InP & GaSb laser chips to meet our customers' specific optical and electrical performance needs. Diodes, bars and packages are tested to meet customer and market performance demands. Typical results and packaging options are shown. Contact SemiNex for additional details or to discuss your specific requirements.

SemiNex Corporation • 153 Andover Street, Suite 201, Danvers, MA 01923 • 978-326-7700 • sales@seminex.com

# High Power Laser Diode TO-Cans



## Specification

TO9-185

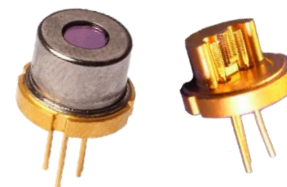

Optical	Symbol	Typ.	Units
Center Wavelength	$\lambda_c$	1360	nm ( $\pm 20$ )
Output Power (<10ns)*	$P_{out}$	36	Watts ( $\pm 10\%$ )
Output Power (150ns)*	$P_{out}$	19	Watts ( $\pm 10\%$ )
Emitter Width	$W$	95	$\mu m$
Spectral Width FWHM	$\Delta\lambda$	10	nm
Slope Efficiency	$\eta$	0.3	W/A
Fast Axis Div.	$\theta_{\perp}$	28	deg FWHM
Slow Axis Div.	$\theta_{\parallel}$	10	deg FWHM
Electrical	Symbol		Units
Power Conversion Eff.	$\eta$	4	%
Operating Current (<10ns)	$I_{op}$	120	A
Operating Current (150ns)	$I_{op}$	60	A
Threshold Current	$I_{TH}$	0.5	A
Operating Voltage	$V_{op}$	8	V
Duty Cycle	DC	0.1	%
Mechanical	Symbol	Range	Units
Operating Temp.**		-40 to 60	$^{\circ}C$
Storage Temp.		-40 to 80	$^{\circ}C$

\*Specified values are rated at a constant heat sink temperature of 20°C.

\*\*High temperature operation will reduce performance and MTTF.  
Unless otherwise indicated all values are nominal.

\*Available Lenses & Caps

Part Number	Description*
TO9-185	TO9 Uncapped, Fast Axis: 30° FWHM, Slow Axis: 10° FWHM, Pout: 18W (150ns)
TO9-185-114	TO9 4.6mm Tall Cap, Fast Axis: 30° FWHM, Slow Axis: 10° FWHM, Pout: 18W (150ns)
TO9-185-115	TO9 5.8mm Tall Cap, Lens Collimated, Fast Axis: 0.3° FWHM, Slow Axis: 10° FWHM, Pout: 18W (150ns)
TO9-185-140	TO-9 5.8mm Tall Cap, Lens Matched f=171um, 5.0mm Lg, Fast Axis: 10°, Slow Axis: 10° FWHM, Pout: 18W (150ns)
TO9-185-161	TO9 5.8mm Tall Cap, Fast Axis: 30° FWHM, Slow Axis: 10° FWHM, Pout: 18W (150ns)

\*Lensing specifications are typical values provided based on best-effort measurements.

# High Power Laser Diode TO-Cans



## SemiNex Laser Diodes TO9-185

### Graphs & Data

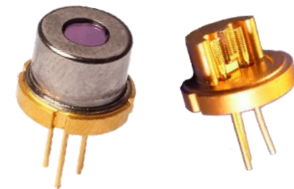

### Typical TO9 L-I-V Characteristics

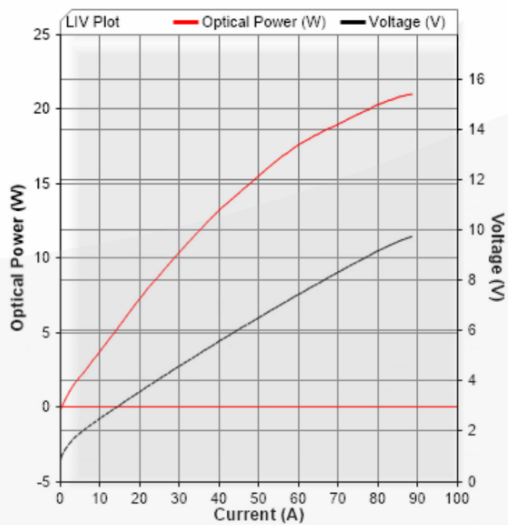

### Typical TO9 Output Spectrum

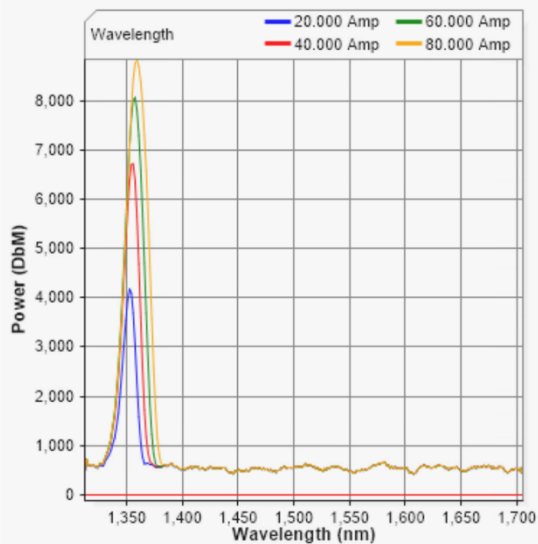

\*Tested with 150nsec pulse @ 0.1% Duty Cycle

SemiNex Corporation • 153 Andover Street, Suite 201, Danvers, MA 01923 • 978-326-7700 • sales@seminex.com

# High Power Laser Diode TO-Cans



## Mechanical Drawing TO9-185

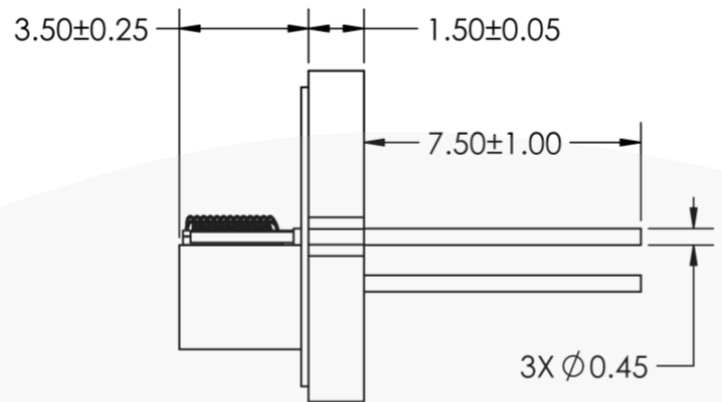
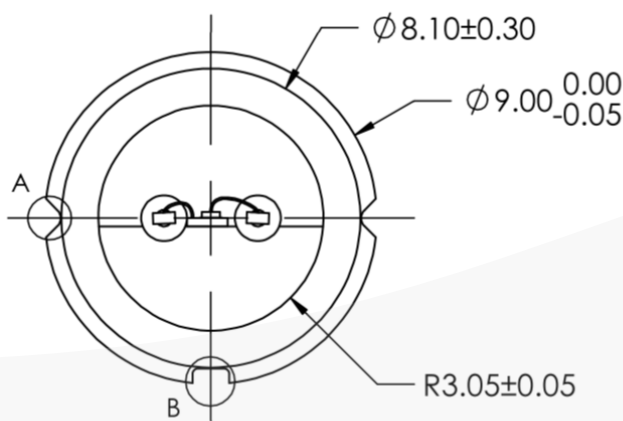

### PIN OUT:

1. LD CATHODE ( - )
2. CASE
3. LD ANODE ( + )

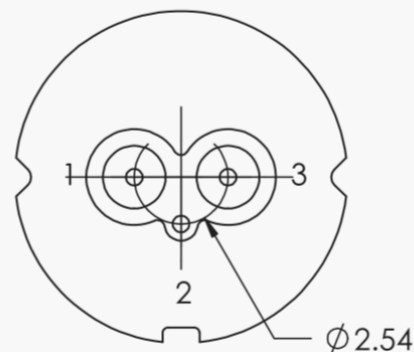

All statements, technical information and recommendations related to the product herein are based upon information believed to be reliable or accurate. The accuracy or completeness herein is not guaranteed, and no responsibility is assumed for any inaccuracies. The user assumes all risks and liability whatsoever in connection with the use of a product or its application. SemiNex Corporation reserves the right to change at any time without notice the design, specification, deduction, fit or form of its described herein, including withdrawal at any time of a product offered for sale herein. Users are encouraged to visit [www.seminex.com](http://www.seminex.com) for the latest data. SemiNex Corporation makes no representations that the products herein are free from any intellectual property claims of others. Please contact SemiNex for more information. 2024 SemiNex Corporation



SemiNex Corporation • 153 Andover Street, Suite 201, Danvers, MA 01923 • 978-326-7700 • [sales@seminex.com](mailto:sales@seminex.com)

# High Power Laser Diode TO-Cans



## Mechanical Drawing

TO9-185-115

TO9-185-140

TO9-185-161

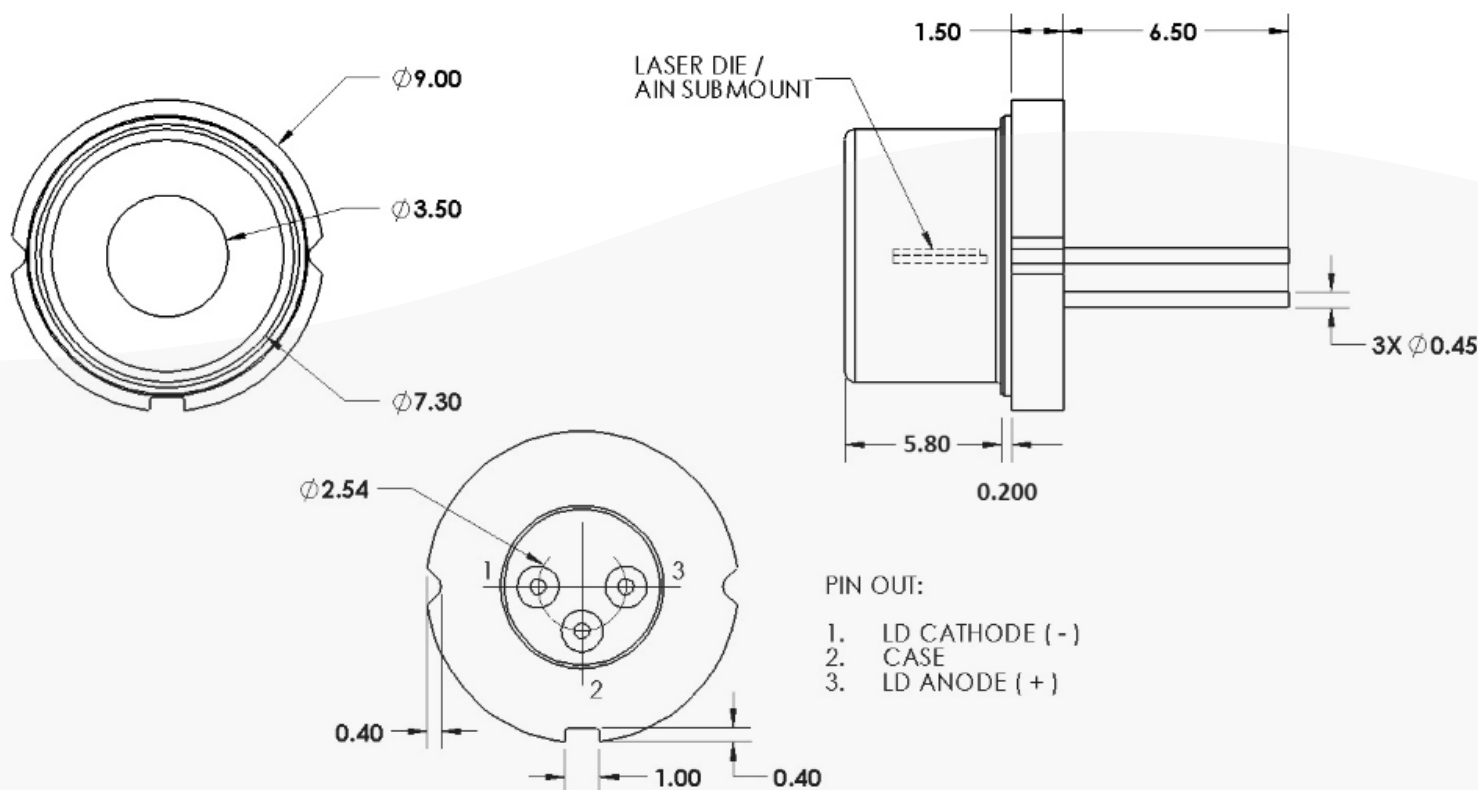

All statements, technical information and recommendations related to the product herein are based upon information believed to be reliable or accurate. The accuracy or completeness herein is not guaranteed, and no responsibility is assumed for any inaccuracies. The user assumes all risks and liability whatsoever in connection with the use of a product or its application. SemiNex Corporation reserves the right to change at any time without notice the design, specification, deduction, fit or form of its described herein, including withdrawal at any time of a product offered for sale herein. Users are encouraged to visit [www.seminex.com](http://www.seminex.com) for the latest data. SemiNex Corporation makes no representations that the products herein are free from any intellectual property claims of others. Please contact SemiNex for more information. 2024 SemiNex Corporation



SemiNex Corporation • 153 Andover Street, Suite 201, Danvers, MA 01923 • 978-326-7700 • [sales@seminex.com](mailto:sales@seminex.com)

# High Power Laser Diode TO-Cans



## Mechanical Drawing TO9-185-114

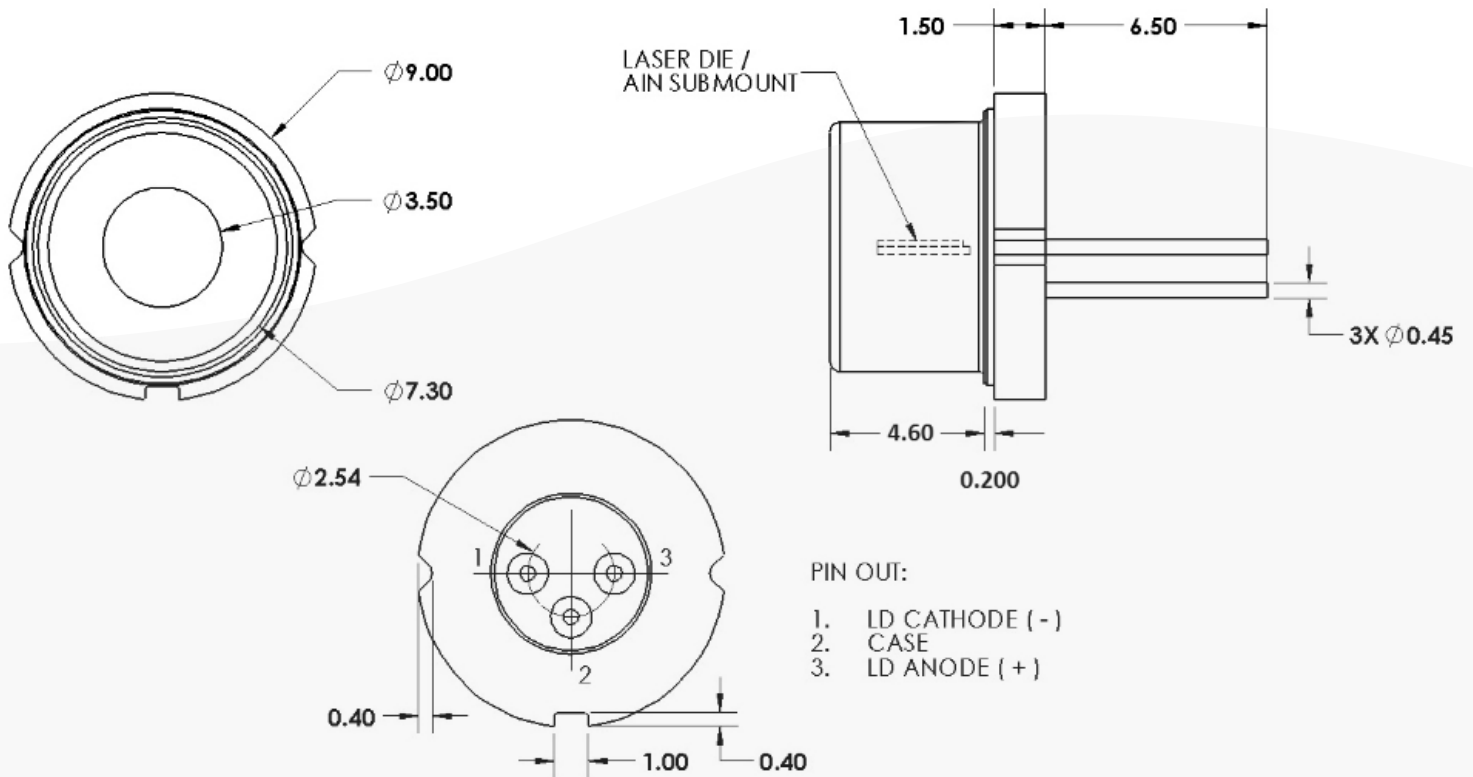
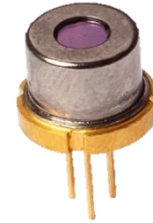

All statements, technical information and recommendations related to the product herein are based upon information believed to be reliable or accurate. The accuracy or completeness herein is not guaranteed, and no responsibility is assumed for any inaccuracies. The user assumes all risks and liability whatsoever in connection with the use of a product or its application. SemiNex Corporation reserves the right to change at any time without notice the design, specification, deduction, fit or form of its described herein, including withdrawal at any time of a product offered for sale herein. Users are encouraged to visit [www.seminex.com](http://www.seminex.com) for the latest data. SemiNex Corporation makes no representations that the products herein are free from any intellectual property claims of others. Please contact SemiNex for more information. 2024 SemiNex Corporation



SemiNex Corporation • 153 Andover Street, Suite 201, Danvers, MA 01923 • 978-326-7700 • [sales@seminex.com](mailto:sales@seminex.com)