

# High Power DFB Laser Diode

## Part Number: CHP-316, CHP-317

### Features

- High Output Power
- High Efficiency @ 50°C
- 1310nm & O-Band available

### Application

- ELSFP, CPO
- Optical Communication
- Data Centers

## Specification



### CHP-316, CHP-317

Optical	Symbol	CHP-316 (typ.)	CHP-317 (typ.)	Units
Center Wavelength	$\lambda_c$	1310	1310	nm
Output Power @ $I_{op}$ & 50C	P	>150	>200	mW
Output Power @ $I_{op}$ & 25C	P	200	250	mW
Linewidth	$\delta f$	500	500	kHz
Side Mode Suppression Ratio	SMSR	50	50	dB
Relative Intensity Noise	RIN	-150	-150	dB/Hz
Electrical	Symbol			Units
Power Conversion Eff.	$\eta$	30	25	%
Operating Voltage	$V_{op}$	1.6	1.6	V
Operating Current	$I_{op}$	400	600	mA
Threshold Current	$I_{TH}$	30	30	mA
Mechanical	Symbol			Units
Operating Temp.	°C	-20 to 75	-20 to 75	°C
Storage Temp.	°C	-40 to 85	-40 to 85	°C

\*Specified values are rated at a constant heat sink temperature of 20°C.

\*\*High temperature operation will reduce performance and MTTF.



SemiNex delivers the highest available power at infrared wavelengths between 12xx and 19xx nm. When necessary, we will further optimize the design of our InP & GaSb laser chips to meet our customers' specific optical and electrical performance needs. Diodes, bars and packages are tested to meet customer and market performance demands. Typical results and packaging options are shown. Contact SemiNex for additional details or to discuss your specific requirements.

SemiNex Corporation • 153 Andover Street, Suite 201, Danvers, MA 01923 • 978-326-7700 • sales@seminex.com

# High Power DFB Laser Diode

SemiNex Laser Diodes CHP-316, CHP-317

Graphs & Data: 25°C

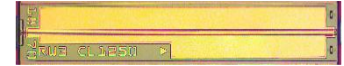

Typical DFB CHP-316  
L-I-V Characteristics

Typical DFB CHP-317  
L-I-V Characteristics

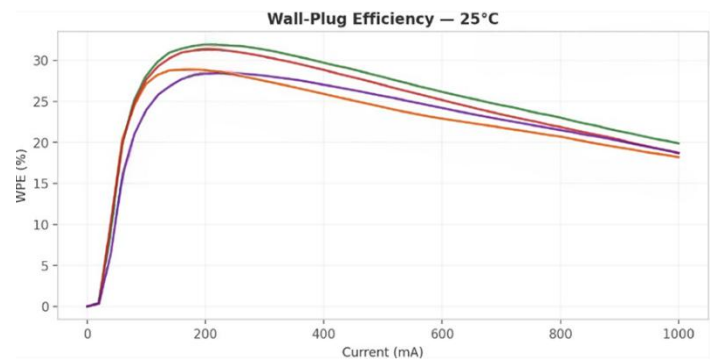
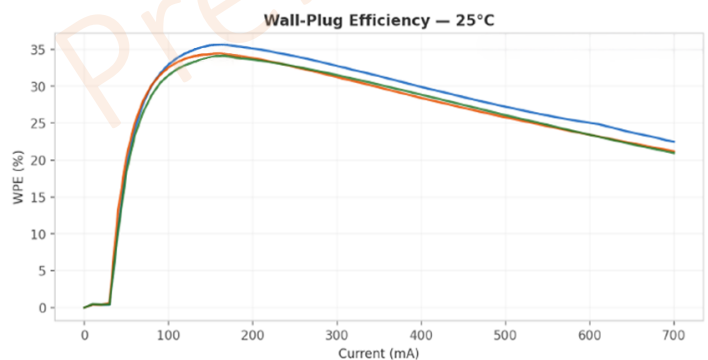
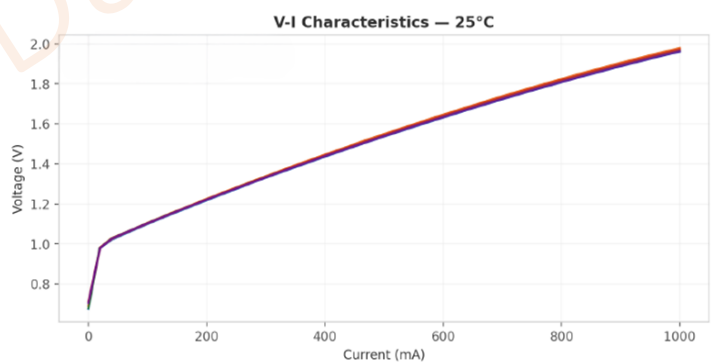
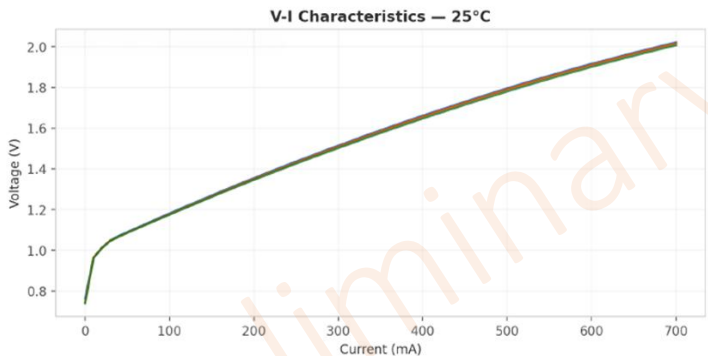
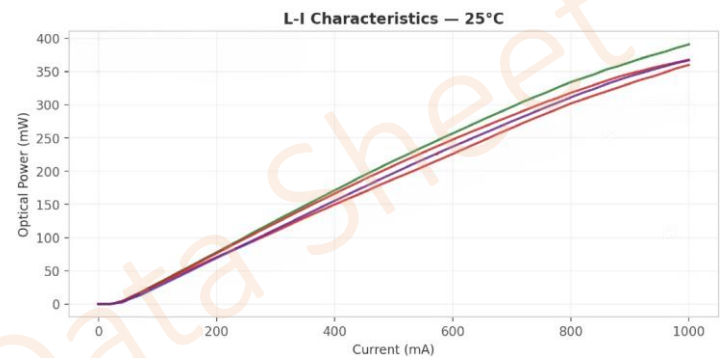
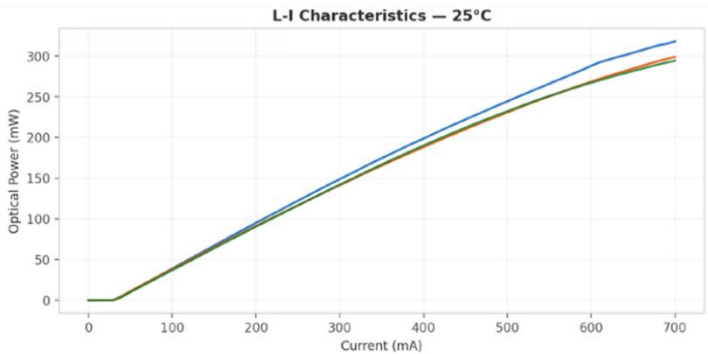

# High Power DFB Laser Diode

SemiNex Laser Diodes CHP-316, CHP-317

Graphs & Data: 50°C



Typical DFB CHP-316  
L-I-V Characteristics

Typical DFB CHP-317  
L-I-V Characteristics

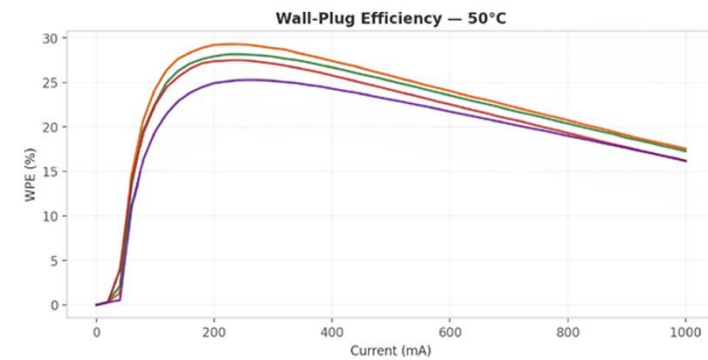
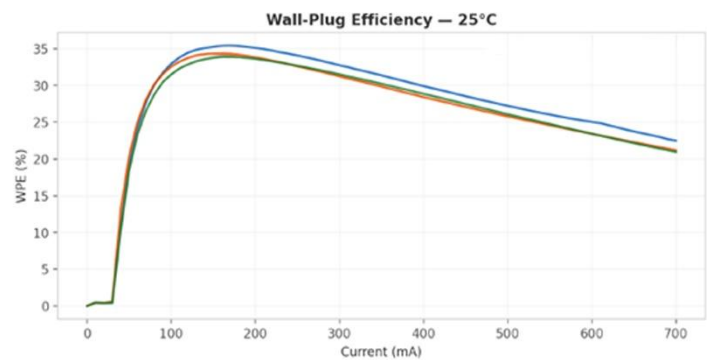
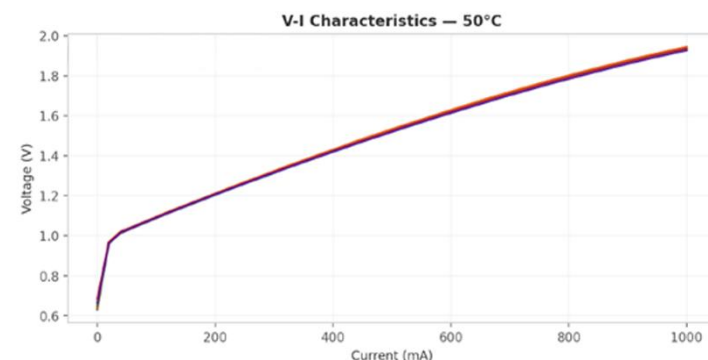
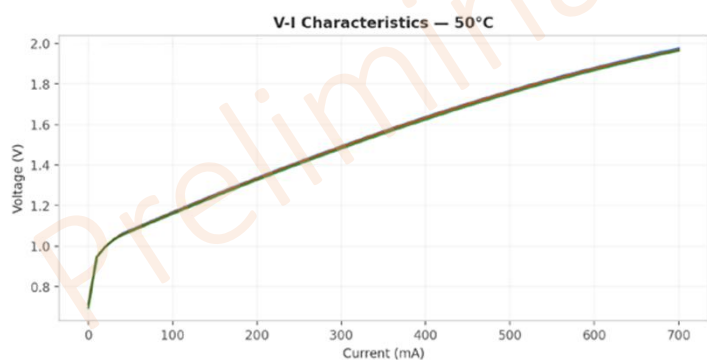
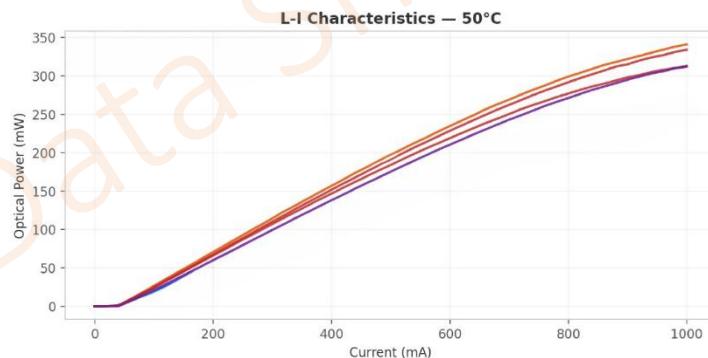
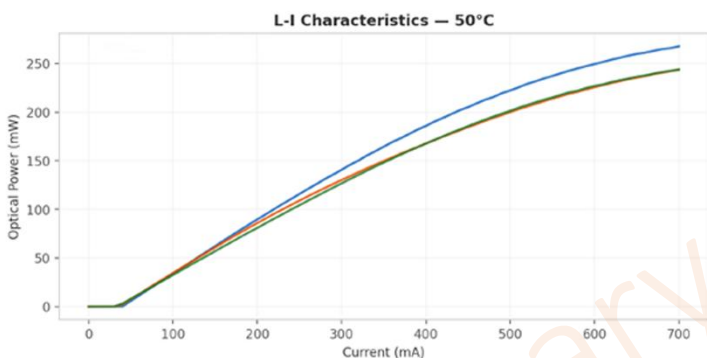

# High Power DFB Laser Diode

## Mechanical Drawing



CHIP ATTRIBUTES	
WAVELENGTH	1310 ± 3nm
CHIP WIDTH	250 ± 10µm
THICKNESS	110 ± 10µm
CHIP LENGTH	1500 ± 10µm for CHP-317
CHIP LENGTH	1000 ± 10µm for CHP-316

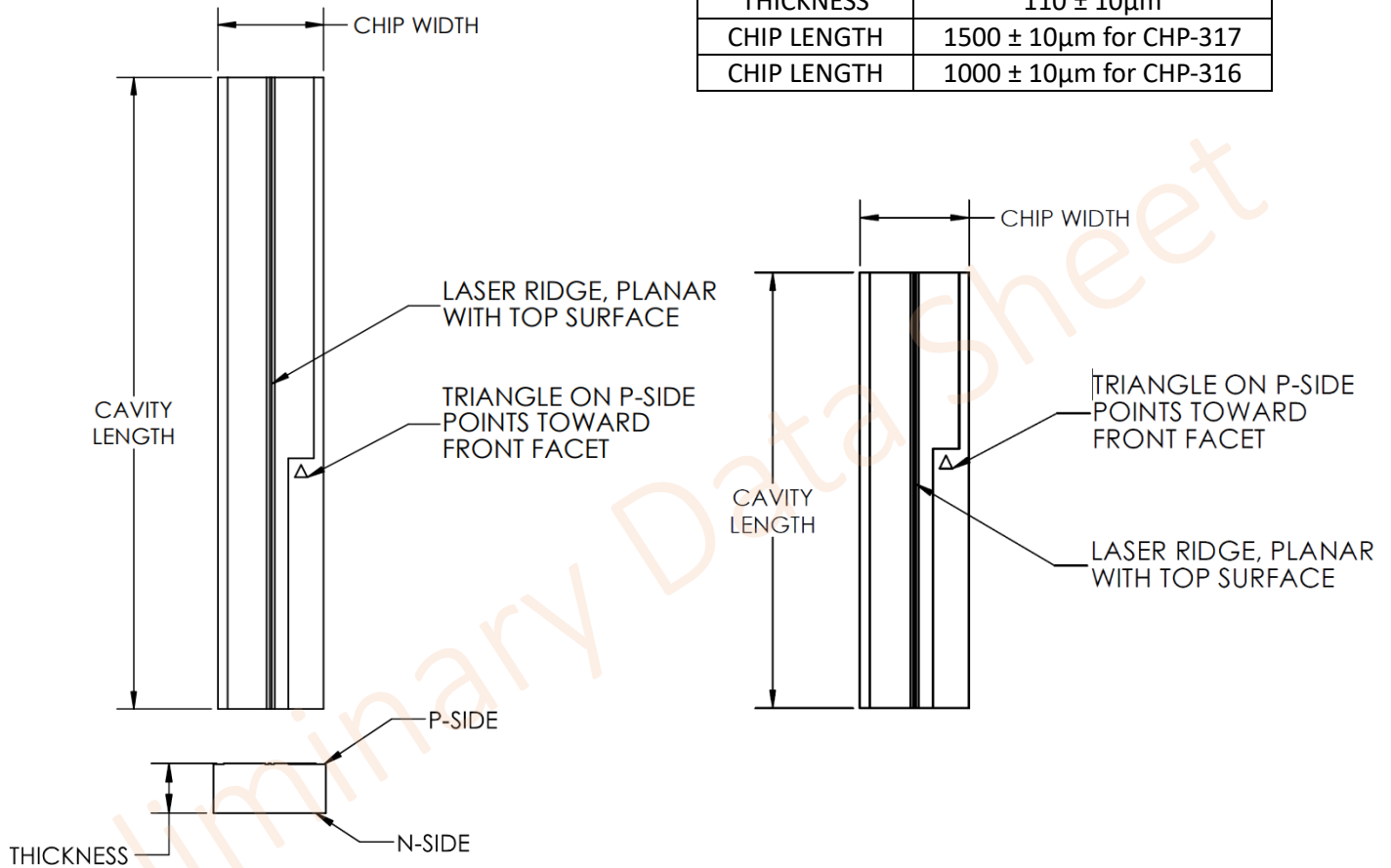

P-METAL			N-METAL		
MATERIAL	THICKNESS (nm)	TOLERANCE (nm)	MATERIAL	THICKNESS (nm)	TOLERANCE (nm)
Ti	50	± 10	Ti	30	± 10
Pt	125	± 25	Pt	125	± 25
Au	250	± 50	Au	400	± 40

All statements, technical information and recommendations related to the product herein are based upon information believed to be reliable or accurate. The accuracy or completeness herein is not guaranteed, and no responsibility is assumed for any inaccuracies. The user assumes all risks and liability whatsoever in connection with the use of a product or its application. SemiNex Corporation reserves the right to change at any time without notice the design, specification, deduction, fit or form of its described herein, including withdrawal at any time of a product offered for sale herein. Users are encouraged to visit [www.seminex.com](http://www.seminex.com) for the latest data. SemiNex Corporation makes no representations that the products herein are free from any intellectual property claims of others. Please contact SemiNex for more information. 2024 SemiNex Corporation



SemiNex Corporation • 153 Andover Street, Suite 201, Danvers, MA 01923 • 978-326-7700 • [sales@seminex.com](mailto:sales@seminex.com)