

Application Notes: Wavelength-Swept ECL Module

Overview

SemiNex's high-power External Cavity Laser (ECL) Module series features 15 kHz and 100 kHz Lorentzian linewidth models with over 200 mW output in C or O-band, built on SemiNex's Gain Chip and high-power SOA integrated with a Photonic Integrated Circuit.



Below is a typical measurement of the wavelength sweeping logic of our standard Wavelength-Swept laser module. The sweep rate and range can be set using the “built-in function generator” to desired values in our factory. This will lead to a mode-hopping-free continuous wavelength-swept mode with high linearity, which is typically used for FMCW LiDAR, OCT, or OFDR applications.

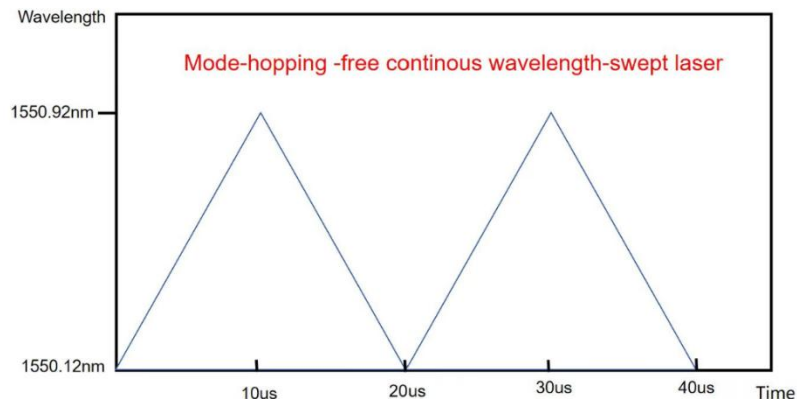

The wavelength swept laser module also has an “external signal input port” (shown in the picture on page 2) which allows to receive an external control signal ($\pm 1V_{pp}$ voltage) for various sweeping rates and ranges for testing purposes. However, for high linearity output, utilizing the built in function generator is recommended.

All statements, technical information and recommendation related to the product herein are based upon information believed to be reliable or accurate. However, the accuracy or completeness hereof is not guaranteed, and no responsibility is assumed for any inaccuracies. The user assumes all risks and liability whatsoever in connection with the use of a product or its application. SemiNex Incorporated reserves the right to change at any time without notice, the design, specification, deduction, fit or form of its described herein, including withdrawal at any time of a product offered for sale herein. SemiNex Incorporated makes no representations that the products herein are free from any intellectual property claims of others. Please contact SemiNex Incorporated for more information. © 2009 Copyright SemiNex Incorporated. All rights reserved.

SemiNex Corporation
153 Andover Street
Suite 201
Danvers, MA 01923
Phone: 978-326-7700
Email: info@seminex.com
Web site: www.seminex.com

The wavelength-swept laser modules can also support a wavelength-step-tuning mode with tuning logic, example shown in the figure below. The tuning range and tuning speed can be varied as per needed by receiving an external modulation function from an external function generator (not provided) via the external signal input port. The input signal must be in a waveform of +/- 1Vpp voltage.

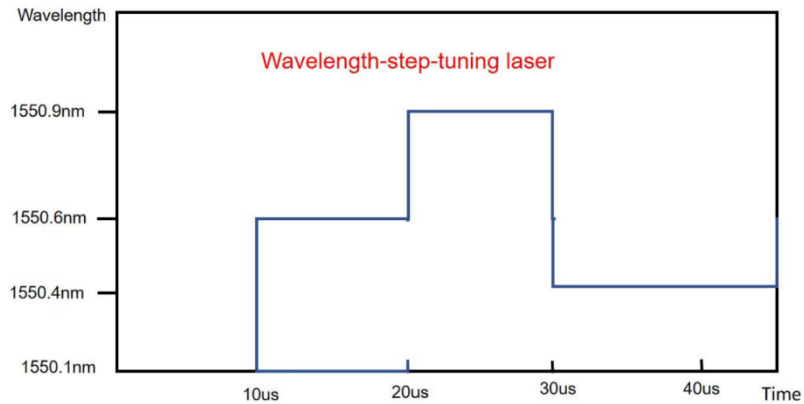

ECL Module Mechanical Specification

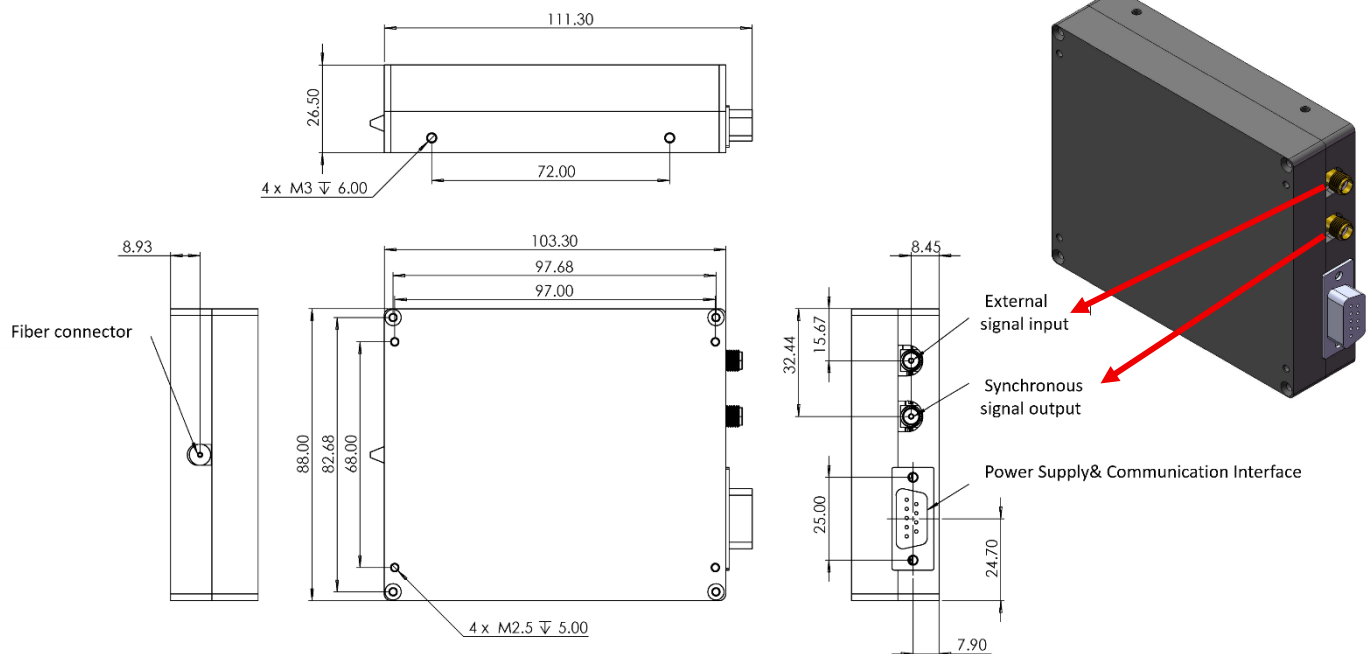

All statements, technical information and recommendation related to the product herein are based upon information believed to be reliable or accurate. However, the accuracy or completeness hereof is not guaranteed, and no responsibility is assumed for any inaccuracies. The user assumes all risks and liability whatsoever in connection with the use of a product or its application. SemiNex Incorporated reserves the right to change at any time without notice, the design, specification, deduction, fit or form of its described herein, including withdrawal at any time of a product offered for sale herein. SemiNex Incorporated makes no representations that the products herein are free from any intellectual property claims of others. Please contact SemiNex Incorporated for more information. © 2009 Copyright SemiNex Incorporated. All rights reserved.

SemiNex Corporation
 153 Andover Street
 Suite 201
 Danvers, MA 01923
 Phone: 978-326-7700
 Email: info@seminex.com
 Web site: www.seminex.com

Dimensions	L×W×H=111.3×88×26.5mm
Fiber Type	PMF
Fiber Connector	FC/APC
Power Supply& Communication Interface	DB9 Male (see below)
Synchronous signal output	OUT (SMA)
External signal input	IN (SMA)

DB9 Connector Pin Definition									
PIN#	1	2	3	4	5	6	7	8	9
Definition	5V	TX	RX	NC	GND	NC	NC	NC	Enable when GND

Supplied Hardware:

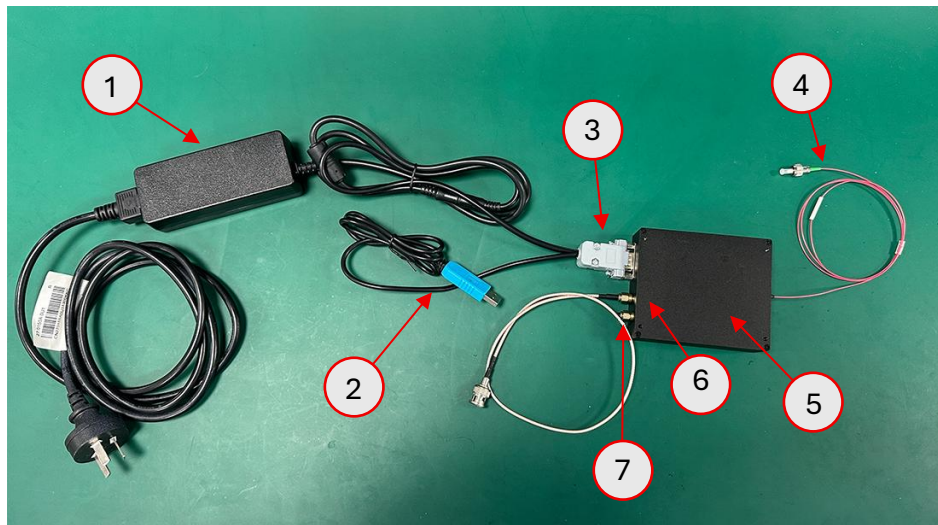

Item#	Hardware Description
1	Power Cable
2	USB Computer Cable
3	Internal DB9 Connector
4	Fiber Optical Output
5	Wavelength Swept Module
6	Synchronous Signal Output with Cable
7	External Signal Input

All statements, technical information and recommendation related to the product herein are based upon information believed to be reliable or accurate. However, the accuracy or completeness hereof is not guaranteed, and no responsibility is assumed for any inaccuracies. The user assumes all risks and liability whatsoever in connection with the use of a product or its application. SemiNex Incorporated reserves the right to change at any time without notice, the design, specification, deduction, fit or form of its described herein, including withdrawal at any time of a product offered for sale herein. SemiNex Incorporated makes no representations that the products herein are free from any intellectual property claims of others. Please contact SemiNex Incorporated for more information. © 2009 Copyright SemiNex Incorporated. All rights reserved.

SemiNex Corporation
 153 Andover Street
 Suite 201
 Danvers, MA 01923
 Phone: 978-326-7700
 Email: info@seminex.com
 Web site: www.seminex.com

Hardware Setup

To begin the hardware setup of the ECL Wavelength Swept Module using the internal sweeping signal, follow the assembly steps below:

- 1) Connect the DB9 connector (item#3) to the Wavelength Swept laser module (item#5), its cable to an AC power source (item#1), and hook up the USB computer cable to a control computer.
- 2) Connect the optical fiber (item#4) with the laser output connector (FC/APC). Use an optical power meter to test the power of the laser module.
- 3) Connect the synchronization signal output port (SMA) with a signal cable (item#6). The signal cable can be used interchangeably to connect both the synchronization signal output and the external signal input port (item#7) with the signal cable. Use an oscilloscope to analyze the amplitude and waveform of the beat signal, as shown in the following example:

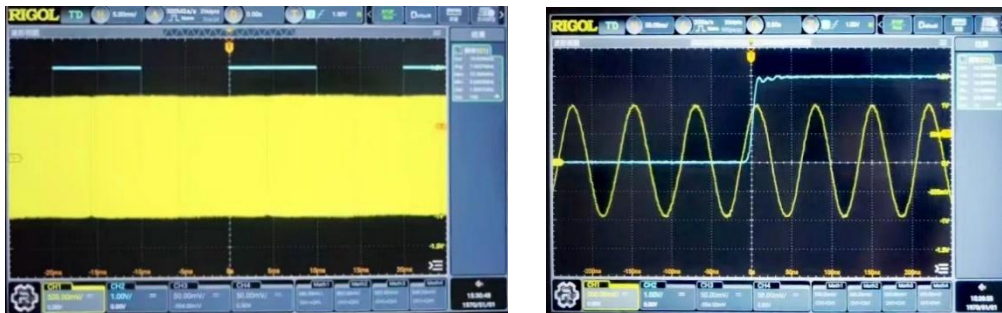

- 4) Before shutting down, turn off the switch of the power socket located on the laser module (item#5), and then disconnect the power cable (item#1) from the laser module.

All statements, technical information and recommendation related to the product herein are based upon information believed to be reliable or accurate. However, the accuracy or completeness hereof is not guaranteed, and no responsibility is assumed for any inaccuracies. The user assumes all risks and liability whatsoever in connection with the use of a product or its application. SemiNex Incorporated reserves the right to change at any time without notice, the design, specification, deduction, fit or form of its described herein, including withdrawal at any time of a product offered for sale herein. SemiNex Incorporated makes no representations that the products herein are free from any intellectual property claims of others. Please contact SemiNex Incorporated for more information. © 2009 Copyright SemiNex Incorporated. All rights reserved.

SemiNex Corporation
153 Andover Street
Suite 201
Danvers, MA 01923
Phone: 978-326-7700
Email: info@seminex.com
Web site: www.seminex.com

Software Setup

The software is supplied separately via email in a Zip file.

- 1) Unzip the host computer file package SNXLaserDriver – Client-En.zip

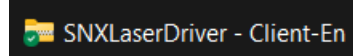

- 2) Double-click to run the “main” application software



- 3) Host computer connection

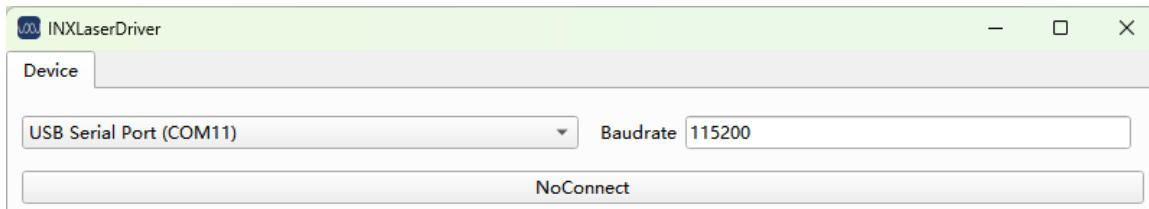

As shown above, select the corresponding module port (item#2), Baudrate is 115200, click on “NoConnect” to connect the module, and when NoConnect changes to Connect, it means the module is successfully connected to the host computer.

- 4) Internal modulation waveform selection AND External modulation selection as below:

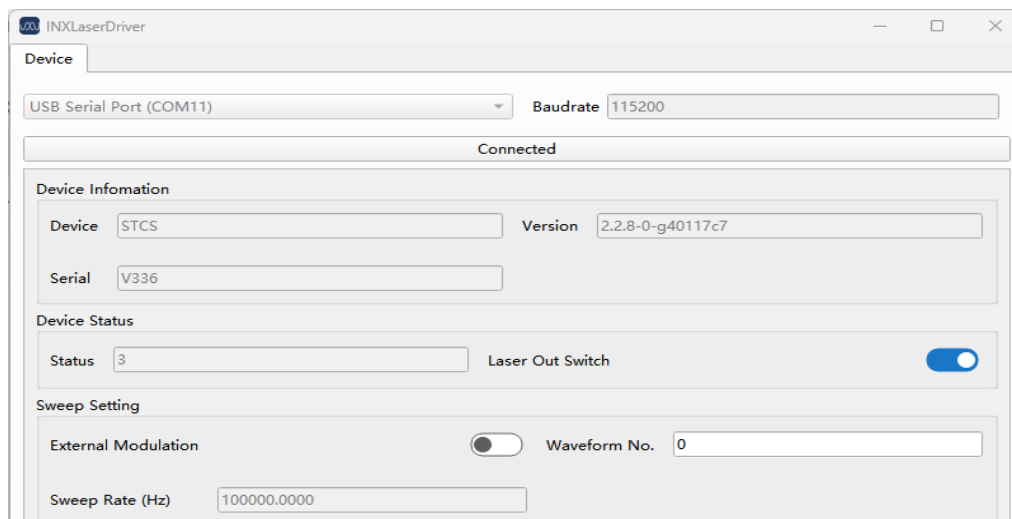

All statements, technical information and recommendation related to the product herein are based upon information believed to be reliable or accurate. However, the accuracy or completeness hereof is not guaranteed, and no responsibility is assumed for any inaccuracies. The user assumes all risks and liability whatsoever in connection with the use of a product or its application. SemiNex Incorporated reserves the right to change at any time without notice, the design, specification, deduction, fit or form of its described herein, including withdrawal at any time of a product offered for sale herein. SemiNex Incorporated makes no representations that the products herein are free from any intellectual property claims of others. Please contact SemiNex Incorporated for more information. © 2009 Copyright SemiNex Incorporated. All rights reserved.

SemiNex Corporation
153 Andover Street
Suite 201
Danvers, MA 01923
Phone: 978-326-7700
Email: info@seminex.com
Web site: www.seminex.com

Notes:

- When the external modulation is in the stop state, the module automatically switches to the internal modulation state. Waveform NO is used to select different internal modulation waveforms. The waveform sweep rate is a feedback value and cannot be changed. If you need to change it, please refer to the test report and change the configuration series 0-1 to automatically switch to the corresponding waveform and sweep rate.
- Laser Out Switch controls the module's output start and stop. When turned on, the module is in normal working state. When turned off, the module output is completely off and there is no optical power output.
- External Modulation controls the module's external modulation start and stop. After turning on the external modulation, the internal modulation automatically stops and switches to the external modulation state. **Note that the external modulation signal voltage must be less than $\pm 1V$.**

Disclaimer

Please note that once the Wavelength-Swept laser module is operated via the external signal input and a 3rd party function generator, the overall performance of the laser module is the responsibility of the end user. SemiNex will not guarantee the performance of the laser module.

All statements, technical information and recommendation related to the product herein are based upon information believed to be reliable or accurate. However, the accuracy or completeness hereof is not guaranteed, and no responsibility is assumed for any inaccuracies. The user assumes all risks and liability whatsoever in connection with the use of a product or its application. SemiNex Incorporated reserves the right to change at any time without notice, the design, specification, deduction, fit or form of its described herein, including withdrawal at any time of a product offered for sale herein. SemiNex Incorporated makes no representations that the products herein are free from any intellectual property claims of others. Please contact SemiNex Incorporated for more information. © 2009 Copyright SemiNex Incorporated. All rights reserved.

SemiNex Corporation
153 Andover Street
Suite 201
Danvers, MA 01923
Phone: 978-326-7700
Email: info@seminex.com
Web site: www.seminex.com