

QLD1a61-xyyPzWtt series

1μm 100-300mW DFB Laser BFY Module under ns Pulsed Operation

C00281-02 March 2024



1. DESCRIPTION

The QLD1a61-xyyPzWtt series is a high power 1μm-wavelength range distributed feedback (DFB) laser under ns pulsed operation for use in seeder for fiber lasers and sensing applications. The laser is assembled into a 14-pin butterfly package with an optical isolator, a monitor PD and a thermo-electric cooler.

2. FEATURES

- Single longitudinal mode operation
- High peak output power of 300mW under pulsed operation
- 3-20ns pulse width@300mW and 3-100ns pulse width@100mW available
- Fiber-pigtailed 14-pin butterfly package with a monitor PD and a TEC
- Optical isolator integration
- Polarization maintaining fiber integration

3. APPLICATIONS

- Seeder for fiber lasers
- Sensing

4. ABSOLUTE MAXIMUM RATINGS

PARAMETER	SYMBOL	RATING	UNIT
Optical Output power (CW)	P_f	50	mW
LD Forward Current (CW)	I_F	250	mA
Peak Output power (Pulse 10 ns/1MHz)	P_{f_pulse} 300mW verison	450	mW
	P_{f_pulse} 100mW verison	150	mW
LD Peak Current (Pulse 10 ns/1MHz)	I_{F_pulse} 300mW verison	2	A
	I_{F_pulse} 100mW verison	600	mA
LD Reverse Voltage	V_{RLD}	2	V
TEC Drive Current	I_{TEC}	2	A
TEC Drive Voltage	V_{TEC}	4.3	V
Operation Temperature	T_c	0 to 60	°C
Storage Temperature	T_{stg}	-40 to 85	°C
Lead Soldering Temperature (10 s)	T_{sld}	260	°C

5. OPTICAL AND ELECTRICAL CHARACTERISTICS
5-1. 300mW version: QLD1a61-xxC0PzWtt

 ($T_{LD} = 25^{\circ}\text{C}$, unless otherwise specified)

PARAMETER	SYMBOL	TEST CONDITION	MIN	TYP	MAX	UNIT
Peak Wavelength	λ_p	CW, $P_f=30\text{ mW}$	λ_p-5 (*2)	λ_p (*1)	λ_p+5 (*2)	nm
Temperature Coefficient of λ_p	$d\lambda_p/dT$	CW / Pulsed	-	0.08	-	nm/K
Threshold Current	I_{th}	CW / Pulsed	-	15	-	mA
CW Fiber Output Power	P_f	CW	30	-	-	mW
CW Operation Voltage	V_{op}	CW, $P_f=30\text{ mW}$	-	1.8	-	V
Pulsed Peak Output Power	P_{f_peak}	Pulsed, $I_{f_peak}=1.5\text{ A}$	300	340	-	mW
Pulsed Averaged Output Power	P_{f_ave}	Pulsed 10 ns/100kHz/1.5A	300	340	-	μW
Pulse Width	t_{pw}	Pulsed, 100kHz/1.5A	3	-	20	ns
Repetition rate	RR	Pulsed, 20 ns/1.5A	-	-	1(*3)	MHz
Sidemode Suppression Ratio	SMSR	CW, $P_f=30\text{ mW}$	30	40	-	dB
		Pulsed 3 ns / 100 kHz / $P_{f_peak}=300\text{ mW}$	25	30	-	dB
Polarization Extinction Ratio	PER	CW	15	20	-	dB
Monitor PD Current	I_m	CW, $P_f=30\text{ mW}$	-	300	-	μA
Thermistor Resistance	R_{th}	$T_{LD} = 25^{\circ}\text{C}$, B=3900K	9.5	10	10.5	k Ω

(*1) Available peak wavelength is from 1018 to 1122 nm and 1140 to 1188 nm.

(*2) Tighter wavelength tolerance of +/- 1nm and +/- 0.5nm is available as an option. Refer to product part number according to wavelength tolerance

(*3) Higher repetition rate is available with proper adjustment of a peak current and pulse width. Please ask QDL for more detail.

5-2. 100mW version: QLD1a61-xxA0PzWtt

 ($T_{LD} = 25^{\circ}\text{C}$, unless otherwise specified)

PARAMETER	SYMBOL	TEST CONDITION	MIN	TYP	MAX	UNIT
Peak Wavelength	λ_p	CW, $P_f=30$ mW	λ_p-5 (*2)	λ_p (*1)	λ_p+5 (*2)	nm
Temperature Coefficient of λ_p	$d\lambda_p/dT$	CW / Pulsed	-	0.08	-	nm/K
Threshold Current	I_{th}	CW / Pulsed	-	15	-	mA
CW Fiber Output Power	P_f	CW	30	-	-	mW
CW Operation Voltage	V_{op}	CW, $P_f=30$ mW	-	1.8	-	V
Pulsed Peak Output Power	P_{f_peak}	5 ns / 100 kHz	-	100	-	mW
Pulsed Averaged Output Power	P_{f_ave}	Pulsed 10 ns/100kHz/300 mA	-	100	-	μ W
Pulse Width	t_{pw}	Pulsed, 100kHz//300 mA	3	-	100	ns
Repetition rate	RR	Pulsed, 100 ns/ 300 mA	-	-	1(*3)	MHz
Sidemode Suppression Ratio	SMSR	CW, $P_f=30$ mW	30	40	-	dB
		Pulsed 4 ns / 1 MHz / $P_{f_peak}=50$ mW	30	40	-	dB
Polarization Extinction Ratio	PER	CW	15	20	-	dB
Monitor PD Current	I_m	CW, $P_f=30$ mW	-	300	-	μ A
Thermistor Resistance	R_{th}	$T_{LD} = 25^{\circ}\text{C}$, B=3900K	9.5	10	10.5	k Ω

(*1) Available peak wavelength is from 1018 to 1122 nm and 1140 to 1188 nm .

(*2) Tighter wavelength tolerance of +/- 1nm and +/- 0.5nm is available as an option. Refer to product part number according to wavelength tolerance

(*3) Higher repetition rate is available with proper adjustment of a peak current and pulse width. Please ask QDL for more detail.

6. PRODUCT PART NUMBER

6-1 General naming rule

QLD1a61-xyyPzWtt

Symbol	Item	Condition	Parameter
a	Main wavelength range	1axx defines wavelength range in nm	a=0: 10xx nm range a=1: 11xx nm range
xx	Main wavelength range	xx defines the last two digits of the wavelength range in nm	xx=30:1030 nm range xx=53:1053 nm range xx=64:1064 nm range xx=83:1083 nm range (examples)
yy	Output power	Peak output power	yy=A0: 100 mW yy=C0: 300 mW
tt	Wavelength	Detailed specification of wavelength	xx=63: 1063 nm xx=32: 1032 nm (examples)
zW	Wavelength tolerance	wavelength tolerance	none: +/-5 nm W: +/-1 nm TW: +/-0.5 nm

6-2 Connector type

Part Number	Fiber Type	Fiber Diameter	Connector
QLD1a61-xyyPzWtt	Polarization maintaining fiber	900um	FC/APC
QLD1a61-xyyPzWtt11		250um	Ferrule/APC

6-3 Examples of product part number

Examples of product name	
Part Number	Peak Wavelength (nm)
QLD1061-64A0PW60	1060nm +/-1nm, 100mW, 900um Fiber
QLD1061-30C0PTW3211	1032nm +/-0.5nm, 300mW, 250um Fiber
QLD1161-22A0PW2211	1122nm +/-1nm, 100mW, 250um Fiber
QLD1061-83A0P	1083nm +/-5nm, 300mW, 900um Fiber

7. OUTLINE DRAWING

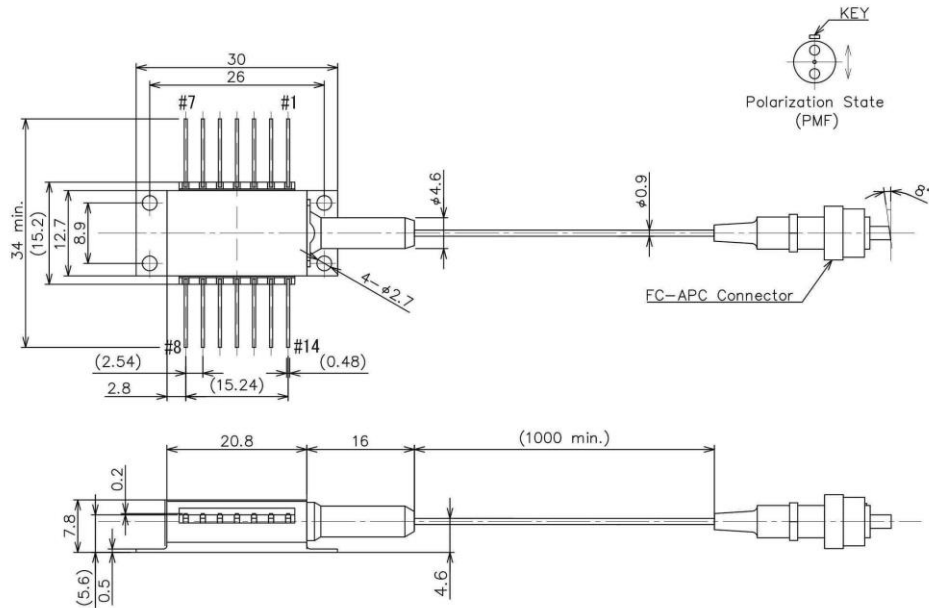

(a) 900um fiber diameter and FC/APC connector type (QLD1a61-xyyPzWtt)

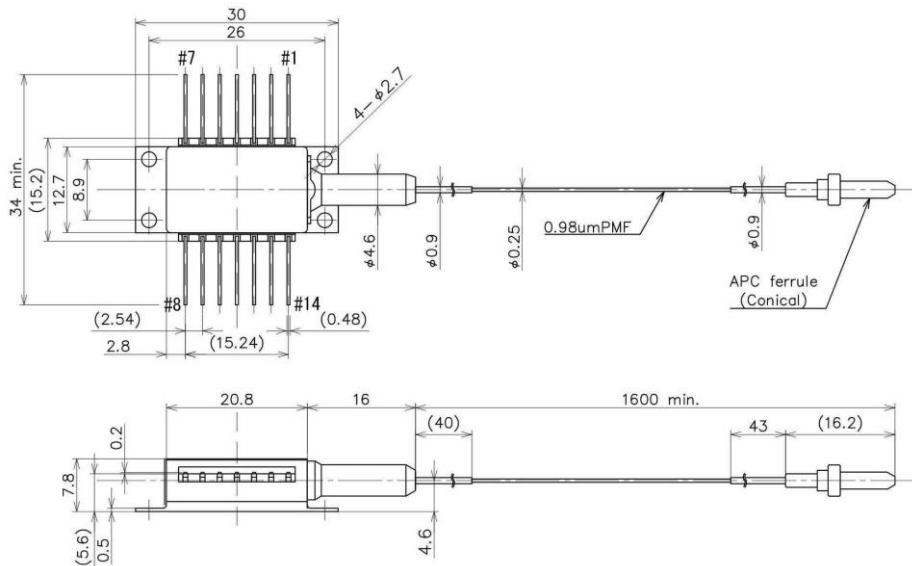

(b) 250um fiber diameter and ferrule type (QLD1a61-xyyPzWtt11)

8. PIN CONFIGURATION

No.	Description	No.	Description
1	TEC (+)	8	NC
2	Thermistor	9	NC
3	PD Anode	10	Laser Anode
4	PD Cathode	11	Laser Cathode
5	Thermistor	12	NC
6	NC	13	Case Ground
7	NC	14	TEC (-)

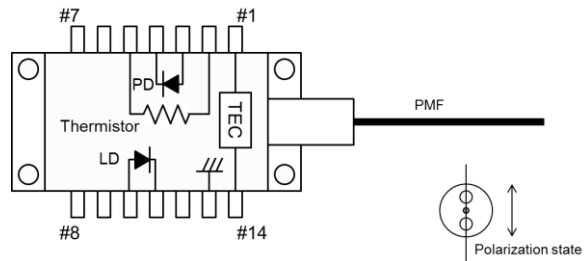

9. NOTICE

• Safety Information

This product is classified as Class 4 laser product, and complies with 21 CFR Part 1040.10.

Please do not take a look at laser lighting in operations since laser devices may cause troubles to human eyes.

Please do not eat, burn, break and make chemical process of the products since they contain GaAs material.

• Handling products

Semiconductor lasers are easily damaged by external stress such as excess temperature and ESD.

Please pay attention to handling products, and use within range of maximum ratings.

QD Laser takes no responsibility for any failure or unusual operation resulting from improper handling, or unusual physical or electrical stress.

• RoHS

This product conforms to RoHS compliance related Directive (EU) 2015/863.

	<p>LASER DIODE</p>
<p>INVISIBLE LASER RADIATION AVOID DIRECTION EXPOSURE TO BEAM</p> <p>MAXIMUM OUTPUT 1 W WAVELENGTH 1000~1200 nm CLASS IV LASER PRODUCT</p>	<p>AVOID EXPOSURE-Invisible Laser Radiation is emitted from this aperture.</p>
<p>This product complies with 21 CFR Part 1040.10 and 1040.11 except for deviations pursuant to Laser Notice No.50, dated June 24, 2007</p> <p>QD Laser, Inc. 1-1 Minamiwataridacho, Kawasaki-ku, Kawasaki, Kanagawa, 210-0855 Japan</p>	

QD Laser, Inc.

Contact : info@qdlaser.com <https://www.qdlaser.com>

Copyright 2022-2024 All Rights Reserved by QD Laser, Inc.

Keihin Bldg. 1F 1-1 Minamiwatarida-cho, Kawasaki-ku, Kawasaki, Kanagawa Zip 210-0855 Japan

All company or product names mentioned herein are trademarks or registered trademarks of their respective owners. Information provided in this data sheet is accurate at time of publication and is subject to change without advance notice.