

# QLD1a61-xx30GzWtt series

1μm-range 50ps DFB Laser BFY Module under gain switched Operation

C00282-02 March 2024



## 1. DESCRIPTION

The QLD1a61-xx30GzWtt series is a 1μm-wavelength range distributed feedback (DFB) laser for use in seeder and sensing applications. The laser is assembled into a 14-pin butterfly package with an optical isolator, a monitor PD and a thermo-electric cooler.

## 2. FEATURES

- Single longitudinal mode operation
- Fiber-pigtailed 14-pin butterfly package with a monitor PD and a TEC
- Optical isolator integration
- Polarization maintaining fiber integration
- 50 ps gain switched optical pulse

## 3. APPLICATIONS

- Seeder for fiber lasers
- Sensing

## 4. ABSOLUTE MAXIMUM RATINGS

PARAMETER	SYMBOL	RATING	UNIT
Optical Output power (Gain switch operation)	$P_p$	150	mW
Optical Output power (CW)	$P_f$	50	mW
LD Forward Current (CW)	$I_F$	250	mA
LD Reverse Voltage	$V_{RLD}$	2	V
TEC Drive Current	$I_{TEC}$	2	A
TEC Drive Voltage	$V_{TEC}$	4.3	V
Operation Temperature	$T_c$	0 to 60	°C
Storage Temperature	$T_{stg}$	-40 to 85	°C
Lead Soldering Temperature (5 s)	$T_{slid}$	230	°C

**5. OPTICAL AND ELECTRICAL CHARACTERISTICS**

 ( $T_{LD} = 25^{\circ}\text{C}$ , unless otherwise specified)

PARAMETER	SYMBOL	TEST CONDITION	MIN	TYP	MAX	UNIT
Optical pulse width	PW	gain switched operation		50	-	ps
Peak output power	$P_p$	gain switched operation	-	100	-	mW
Peak Wavelength	$\lambda_p$	gain switched operation	$\lambda_p-5$ (*2)	$\lambda_p(*1)$	$\lambda_p+5$ (*2)	nm
Pulsed side-mode suppression ratio	SMSR <sub>P</sub>	gain switched operation	-	30	-	dB
Pulsed spectral line width	$\Delta\lambda$	gain switched operation	-	0.1	-	nm
Temperature Coefficient of $\lambda_p$	$d\lambda_p/dT$	CW	-	0.08	-	nm/K
Current Coefficient of $\lambda_p$	$d\lambda_p/dI$	CW	-	0.008	-	nm/mA
Polarization Extinction Ratio	PER	CW, $P_f=30$ mW	15	20	-	dB
Monitor PD Current	$I_m$	CW, $P_f=30$ mW	50	200	1000	$\mu\text{A}$
Thermistor Resistance	$R_{th}$	$T_{LD} = 25^{\circ}\text{C}$ , $B=3900$ K	9.5	10	10.5	k $\Omega$

(\*1) Available peak wavelength is from 1018 to 1122 nm and 1040 to 1188 nm.

(\*2) Tighter wavelength tolerance of +/- 1nm and +/- 0.5nm is available as an option. Refer to product part number according to wavelength tolerance

## 6. PRODUCT PART NUMBER

### 6-1 General naming rule

QLD1a61-xx30GzWtt

Symbol	Item	Condition	Parameter
a	Main wavelength range	1axx defines wavelength range in nm	a=0: 10xx nm range a=1: 11xx nm range
xx	Main wavelength range	xx defines the last two digits of the wavelength range in nm	xx=30: 1030 nm range xx=53: 1053 nm range xx=64: 1064 nm range xx=83: 1083 nm range (examples)
tt	Wavelength	Detailed specification of wavelength	xx=63: 1063 nm xx=32: 1032 nm (examples)
zW	Wavelength tolerance	wavelength tolerance	none: +/-5 nm W: +/-1 nm TW: +/-0.5 nm

### 6-2 Connector type

Part Number	Fiber Type	Fiber Diameter	Connector
QLD1a61-xx30GzWtt	Polarization maintaining fiber	900um	FC/APC
QLD1a61-xx30GzWtt11		250um	Ferrule/APC

### 6-3 Examples of product part number

Examples of product name

Part Number	Peak Wavelength (nm)
QLD1061-6430GW60	1060nm +/-1nm 900um Fiber
QLD1061-3030GTW3211	1032nm +/-0.5nm 250um Fiber
QLD1161-2230GW2211	1122nm +/-1nm 250um Fiber
QLD1061-8330G	1083nm +/-5nm 900um Fiber

## 7. OUTLINE DRAWING

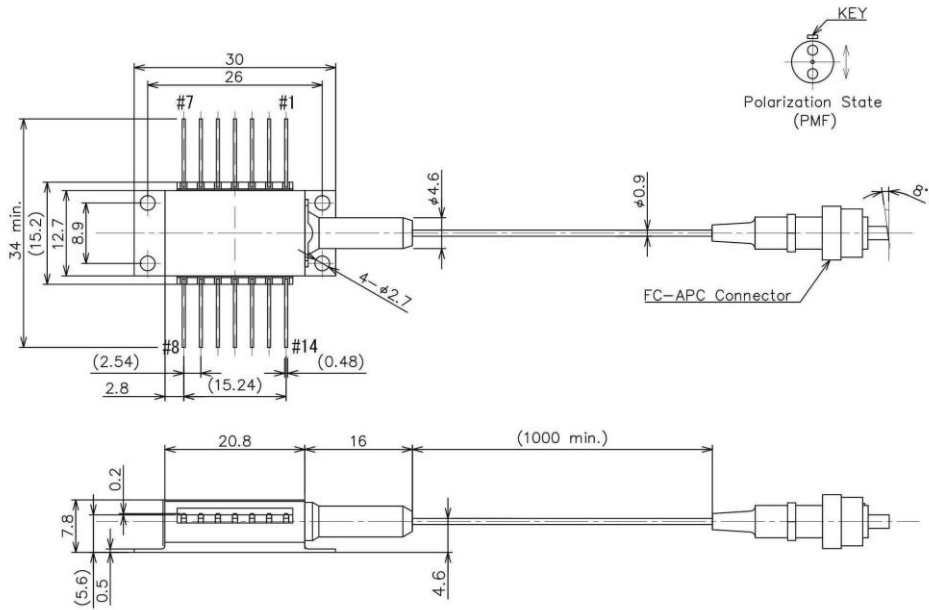

(a) 900um fiber diameter and FC/APC connector type (QLD1a61-xx30GzWtt)

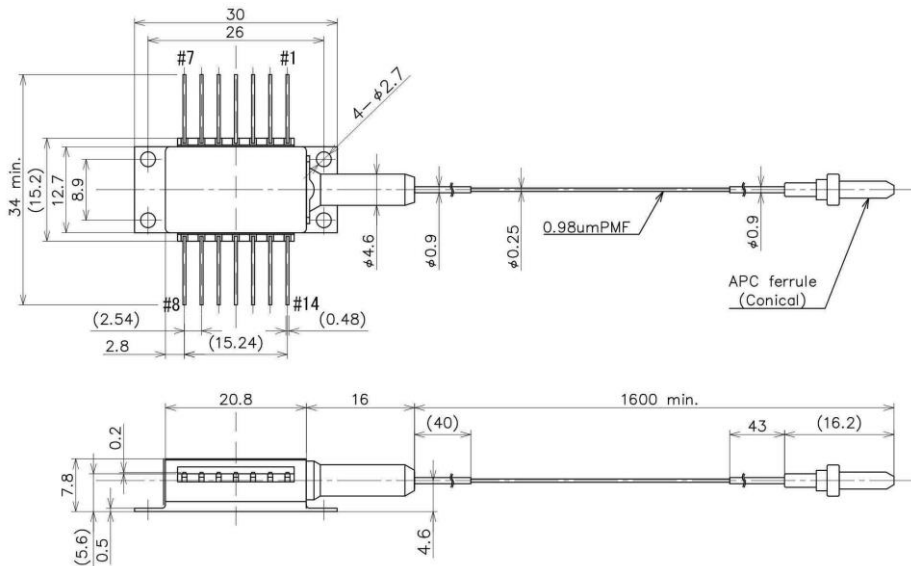

(b) 250um fiber diameter and ferrule type (QLD1a61-xx30GzWtt11)

## 8. PIN CONFIGURATION

No.	Description	No.	Description
1	TEC (+)	8	NC
2	Thermistor	9	NC
3	PD Anode	10	Laser Anode
4	PD Cathode	11	Laser Cathode
5	Thermistor	12	NC
6	NC	13	Case Ground
7	NC	14	TEC (-)

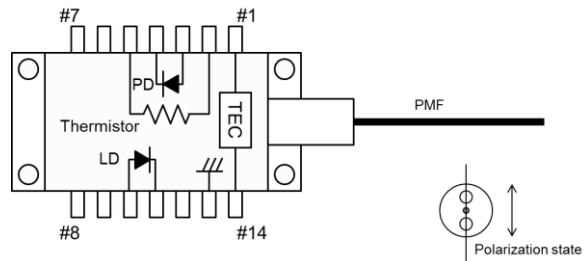

## 9. NOTICE

### • Safety Information

This product is classified as Class 3B laser product, and complies with 21 CFR Part 1040.10.

Please do not take a look at laser lighting in operations since laser devices may cause troubles to human eyes.

Please do not eat, burn, break and make chemical process of the products since they contain GaAs material.

### • Handling products

Semiconductor lasers are easily damaged by external stress such as excess temperature and ESD.

Please pay attention to handling products, and use within range of maximum ratings.

QD Laser takes no responsibility for any failure or unusual operation resulting from improper handling, or unusual physical or electrical stress.

### • RoHS

This product conforms to RoHS compliance related Directive (EU) 2015/863.

	<p>LASER DIODE</p>
<p>INVISIBLE LASER RADIATION AVOID DIRECTION EXPOSURE TO BEAM</p> <p>MAXIMUM OUTPUT 300 mW WAVELENGTH 1000~1200 nm CLASS 3B LASER PRODUCT</p>	<p>AVOID EXPOSURE-Invisible Laser Radiation is emitted from this aperture.</p>
<p>This product complies with 21 CFR Part 1040.10</p> <p><b>QD Laser, Inc.</b></p> <p>1-1 Minamiwataridacho, Kawasaki-ku, Kawasaki, Kanagawa, 210-0855 Japan</p>	

QD Laser, Inc.

Contact : [info@qdlaser.com](mailto:info@qdlaser.com)      <https://www.qdlaser.com>

Copyright 2022-2024 All Rights Reserved by QD Laser, Inc.

Keihin Bldg. 1F 1-1 Minamiwatarida-cho, Kawasaki-ku, Kawasaki, Kanagawa Zip 210-0855 Japan

All company or product names mentioned herein are trademarks or registered trademarks of their respective owners. Information provided in this data sheet is accurate at time of publication and is subject to change without advance notice.