

# QLD106P-64D0 series

1064nm 400mW DFB Laser BFY Module under 1-10 ns Pulsed Operation C00198-03 February 2021



## 1. DESCRIPTION

The QLD106P-64D0 is a high power 1064-nm distributed feedback (DFB) laser under 1-10 ns pulsed operation for use in seeder for fiber lasers and sensing applications. The laser is assembled into a 14-pin butterfly package with an optical isolator, a monitor PD and a thermo-electric cooler.

## 2. FEATURES

- Single longitudinal mode operation at 1064 nm
- High peak output power of 400mW under pulsed operation
- 1-10 ns pulse width available
- Fiber-pigtailed 14-pin butterfly package with a TEC
- Optical isolator integration
- Polarization maintaining fiber integration

## 3. APPLICATIONS

- Seeder for fiber lasers
- Sensing

## 4. ABSOLUTE MAXIMUM RATINGS

PARAMETER	SYMBOL	RATING	UNIT
Optical Output power (CW)	$P_f$	50	mW
LD Forward Current (CW)	$I_F$	250	mA
Peak Output power (Pulse 10 ns/1MHz)	$P_{f\_pulse}$	600	mW
LD Peak Current (Pulse 10 ns/1MHz)	$I_{F\_pulse}$	2	A
LD Reverse Voltage	$V_{RLD}$	2	V
TEC Drive Current	$I_{TEC}$	2	A
TEC Drive Voltage	$V_{TEC}$	4.3	V
Operation Temperature	$T_c$	0 to 60	°C
Storage Temperature	$T_{stg}$	-40 to 85	°C
Lead Soldering Temperature (10 s)	$T_{sld}$	260	°C

**5. OPTICAL AND ELECTRICAL CHARACTERISTICS**

 ( $T_{LD} = 25^{\circ}\text{C}$ , unless otherwise specified)

PARAMETER	SYMBOL	TEST CONDITION	MIN	TYP	MAX	UNIT
Peak Wavelength	$\lambda_p$	CW, $P_f=30$ mW	1059 (*2)	1064 (*1)	1069 (*2)	nm
Temperature Coefficient of $\lambda_p$	$d\lambda_p/dT$	CW / Pulsed	-	0.08	-	nm/K
Threshold Current	$I_{th}$	CW / Pulsed	-	15	30	mA
CW Fiber Output Power	$P_f$	CW	30	-	-	mW
CW Operation Voltage	$V_{op}$	CW, $P_f=30$ mW	-	1.8	-	V
Pulsed Peak Output Power	$P_{f\_peak}$	Pulsed, $I_{f\_peak}=1.6$ A	400	500	-	mW
Pulsed Averaged Output Power	$P_{f\_ave}$	Pulsed 1 ns/100kHz/1.6A	40	-	-	$\mu\text{W}$
		Pulsed 10 ns/100kHz/1.6A	400	-	-	$\mu\text{W}$
Pulse Width	$t_{pw}$	Pulsed	1	-	10	ns
Duty Cycle	D.C.	Pulsed	-	-	1(*3)	%
Sidemode Suppression Ratio	SMSR	CW, $P_f=30$ mW	30	40	-	dB
		Pulsed 1ns/100kHz	25	30	-	dB
Spectral line width	$\Delta\lambda$	Pulsed 1ns/100kHz, @-3dB from peak		0.04		nm
Polarization Extinction Ratio	PER	CW	15	20	-	dB
Monitor PD Current	$I_m$	CW, $P_f=30$ mW	-	300	-	$\mu\text{A}$
Thermistor Resistance	$R_{th}$	$T_{LD} = 25^{\circ}\text{C}$ , $B=3900\text{K}$	9.5	10	10.5	$\text{k}\Omega$

(\*1) Inquire other wavelengths.

(\*2) Tighter wavelength tolerance is available as an option.

(\*3) Higher duty cycle is available with proper adjustment of a peak current. Please ask QD Laser for more detail.

**6. PRODUCT PART NUMBER**

Part Number	Fiber Type	Fiber Diameter	Connector
QLD106P-64D0	Polarization maintaining fiber	900um	FC/APC
QLD106P-64D0-11		250um	Ferrule

## 7. OUTLINE DRAWING

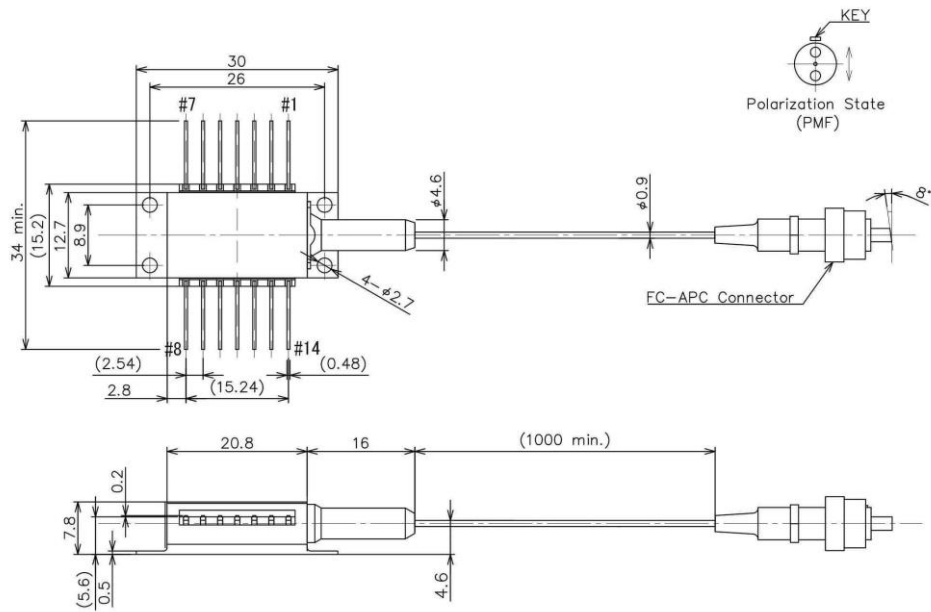

(a) 900um fiber diameter and FC/APC connector type (QLD106P-64D0)

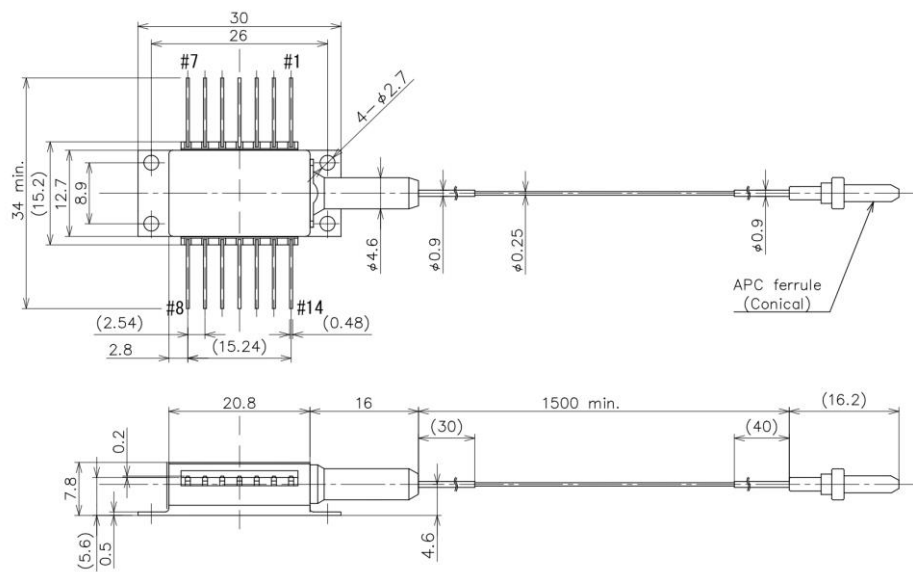

(b) 250um fiber diameter and ferrule type (QLD106P-64D0-11)

## 8. PIN CONFIGURATION

No.	Description	No.	Description
1	TEC (+)	8	NC
2	Thermistor	9	NC
3	PD Anode	10	Laser Anode
4	PD Cathode	11	Laser Cathode
5	Thermistor	12	NC
6	NC	13	Case Ground
7	NC	14	TEC (-)

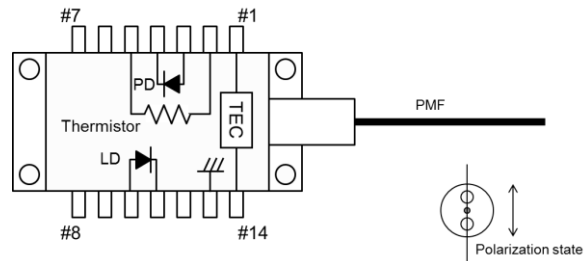

## 9. NOTICE

- Safety Information

This product is classified as Class 3B laser product, and complies with 21 CFR Part 1040.10.

Please do not take a look at laser lighting in operations since laser devices may cause troubles to human eyes.

Please do not eat, burn, break and make chemical process of the products since they contain GaAs material.

- Handling products



Semiconductor lasers are easily damaged by external stress such as excess temperature and ESD.

Please pay attention to handling products, and use within range of maximum ratings.

QD Laser takes no responsibility for any failure or unusual operation resulting from improper handling, or unusual physical or electrical stress.

- RoHS

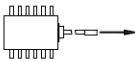
This product conforms to RoHS compliance related Directive (EU) 2015/863.

 <p><b>DANGER</b></p>	<p>LASER DIODE</p> 
 <p>INVISIBLE LASER RADIATION AVOID DIRECTION EXPOSURE TO BEAM</p> <p>MAXIMUM OUTPUT 300 mW WAVELENGTH 1000~1200 nm CLASS 3B LASER PRODUCT</p>	<p><b>AVOID EXPOSURE</b>-Invisible Laser Radiation is emitted from this aperture.</p>
<p>This product complies with 21 CFR Part 1040.10</p> <p><b>QD Laser, Inc.</b></p> <p>1-1 Minamiwataridacho, Kawasaki-ku, Kawasaki, Kanagawa, 210-0855 Japan</p>	

**QD Laser, Inc.**

Contact : [info@qdlaser.com](mailto:info@qdlaser.com)      <https://www.qdlaser.com>

Copyright 2016-2021 All Rights Reserved by QD Laser, Inc.

**Keihin Bldg. 1F 1-1 Minamiwatarida-cho, Kawasaki-ku, Kawasaki, Kanagawa Zip 210-0855 Japan**

All company or product names mentioned herein are trademarks or registered trademarks of their respective owners. Information provided in this data sheet is accurate at time of publication and is subject to change without advance notice.