

## QLD106G-3010 series

1030 nm 20ps DFB Laser Butterfly Package with SMPM connector

C00118-06 November 2022



### 1. DESCRIPTION

The QLD106G-3010 series is a 1030-nm distributed feedback (DFB) laser suitable for short pulsed seed sources including picosecond pulse operation. The laser is assembled into a 7-pin butterfly package with SMPM connector.

### 2. FEATURES

- Single longitudinal mode operation at 1030 nm
- Short pulsed operation of 20 ps
- 7pin butterfly package with SMPM connector

### 3. APPLICATIONS

- Seeder for fiber lasers
- Sensing

### 4. ABSOLUTE MAXIMUM RATINGS

PARAMETER	SYMBOL	RATING	UNIT
Optical Output power (CW)	$P_f$	20	mW
LD Forward Current (CW)	$I_f$	90	mA
LD Reverse Voltage	$V_{RLD}$	2	V
TEC Drive Current	$I_{TEC}$	2	A
TEC Drive Voltage	$V_{TEC}$	4.3	V
Operation Temperature	$T_c$	0 to 60	°C
Storage Temperature	$T_{stg}$	-40 to 85	°C
Lead Soldering Temperature (5 s)	$T_{sld}$	230	°C

### 5. OPTICAL AND ELECTRICAL CHARACTERISTICS

( $T_{LD} = 25^\circ\text{C}$ , unless otherwise specified)

PARAMETER	SYMBOL	TEST CONDITION	MIN	TYP	MAX	UNIT
Peak Wavelength	$\lambda_p$	Pulsed operation	1027*	1030	1033*	nm
Spectral Linewidth	$\Delta\lambda$	@20dB, Pulsed	-	1	-	nm
Pulse Width	PW	-	-	20	-	ps
Averaged Output Power	$P_{f\_ave}$	Pulsed/100MHz	-	0.1	-	mW
Sidemode Suppression Ratio	SMSR	Pulsed	-	30	-	dB
Polarization Extinction Ratio	PER	CW	15	20	-	dB
Thermistor Resistance	$R_{th}$	$T_{LD} = 25^\circ\text{C}$ , B=3930K	9.5	10	10.5	k $\Omega$
RF Input Impedance	$Z_0$	-	-	50	-	$\Omega$
Optical Isolation	-	@1030nm	25	40	-	dB

\* Peak wavelength tolerance of +/- 1 nm is available as an option.

## 6. PRODUCT PART NUMBER

Part Number	Fiber Type	Fiber Diameter	Connector
QLD106G-3010	Polarization maintaining fiber	900 $\mu\text{m}$	FC/APC
QLD106G-3010-11		250 $\mu\text{m}$	Ferrule

## 7. OUTLINE DRAWING

All dimensions in millimeters.

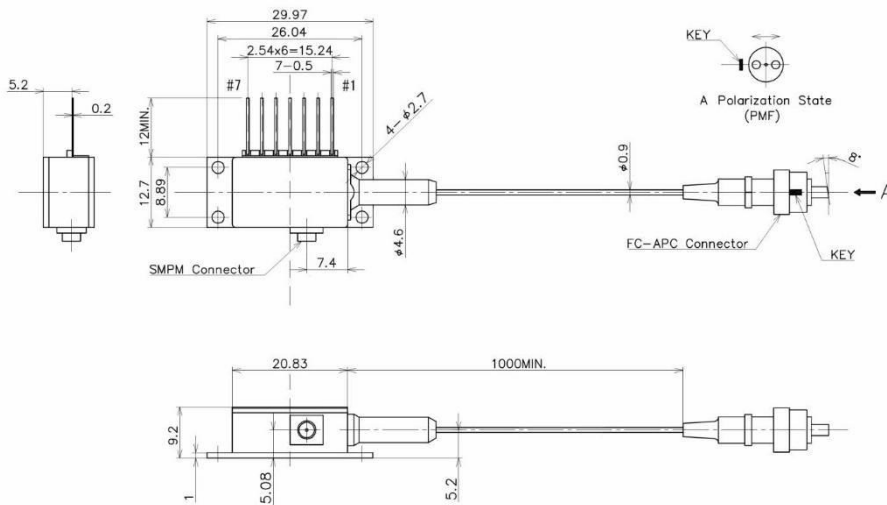

(a) 900- $\mu\text{m}$  fiber diameter and FC/APC connector type (QLD106G-3010)

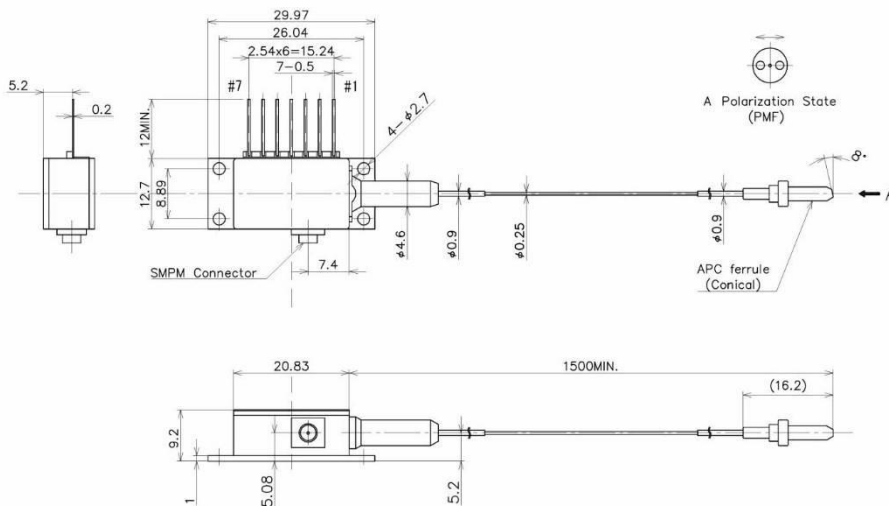

(b) 250- $\mu\text{m}$  fiber diameter and ferrule type (QLD106G-3010-11)

## 8. PIN CONFIGURATION

No.	Description
1	Thermistor
2	Thermistor
3	NC
4	PD Anode
5	PD Cathode
6	TEC(+)
7	TEC(-)
8	LD Anode

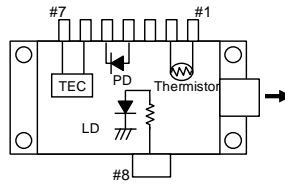

## 9. NOTICE

### • Safety Information

This product is classified as Class 3B laser product, and complies with 21 CFR Part 1040.10.

Please do not take a look at laser lighting in operations since laser devices may cause troubles to human eyes.

Please do not eat, burn, break and make chemical process of the products since they contain GaAs material.

### • Handling products

Semiconductor lasers are easily damaged by external stress such as excess temperature and ESD. Please pay attention to handling products, and use within range of maximum ratings. QD Laser takes no responsibility for any failure or unusual operation resulting from improper handling, or unusual physical or electrical stress.

### • RoHS

This product conforms to RoHS compliance related Directive (EU) 2015/863.

<p><b>DANGER</b></p>	<p>LASER DIODE</p>
<p>INVISIBLE LASER RADIATION AVOID DIRECTION EXPOSURE TO BEAM</p> <p>MAXIMUM OUTPUT 300 mW WAVELENGTH 1000~1200 nm CLASS 3B LASER PRODUCT</p>	<p>AVOID EXPOSURE-Invisible Laser Radiation is emitted from this aperture.</p>
<p>This product complies with 21 CFR Part 1040.10</p> <p><b>QD Laser, Inc.</b></p> <p>1-1 Minamiwataridacho, Kawasaki-ku, Kawasaki, Kanagawa, 210-0855 Japan</p>	

**QD Laser, Inc.**

Contact : [info@qdlaser.com](mailto:info@qdlaser.com)      <https://www.qdlaser.com>

Copyright 2013-2022 All Rights Reserved by QD Laser, Inc.

**Keihin Bldg. 1F 1-1 Minamiwatarida-cho, Kawasaki-ku, Kawasaki, Kanagawa Zip 210-0855 Japan**

All company or product names mentioned herein are trademarks or registered trademarks of their respective owners. Information provided in this data sheet is accurate at time of publication and is subject to change without advance notice.