

# QLD1a61-xyyCzWtt series

1  $\mu\text{m}$ -range 10-30 mW DFB Laser BFY Module under CW Operation

C00280-03 March 2025



## 1. DESCRIPTION

The QLD1a61-xyyCzWtt series is a 1 $\mu\text{m}$ -wavelength range distributed feedback (DFB) laser for use in seeder and sensing applications. The laser is assembled into a 14-pin butterfly package with an optical isolator, a monitor PD and a thermo-electric cooler.

## 2. FEATURES

- Single longitudinal mode operation
- Fiber-pigtailed 14-pin butterfly package with a monitor PD and a TEC
- Optical isolator integration
- Polarization maintaining fiber integration
- CW operation

## 3. APPLICATIONS

- Seeder for fiber lasers
- Sensing

## 4. ABSOLUTE MAXIMUM RATINGS

PARAMETER	SYMBOL	RATING	UNIT
Optical Output power (CW)	$P_f$ 30 mW version	50	mW
	$P_f$ 10 mW version	30	mW
LD Forward Current (CW)	$I_F$ 30 mW version	250	mA
	$I_F$ 10 mW version	150	mA
LD Reverse Voltage	$V_{RLD}$	2	V
TEC Drive Current	$I_{TEC}$	2	A
TEC Drive Voltage	$V_{TEC}$	4.3	V
Operation Temperature	$T_c$	0 to 60	$^{\circ}\text{C}$
Storage Temperature	$T_{stg}$	-40 to 85	$^{\circ}\text{C}$
Lead Soldering Temperature (10 s)	$T_{sld}$	260	$^{\circ}\text{C}$

**5. OPTICAL AND ELECTRICAL CHARACTERISTICS**
**5-1. 10 mW verison: QLD1a61-xx10CzWtt**

 ( $T_{LD} = 25^{\circ}\text{C}$ , unless otherwise specified)

PARAMETER	SYMBOL	TEST CONDITION	MIN	TYP	MAX	UNIT
Peak Wavelength	$\lambda_p$	CW, $P_f=10$ mW	$\lambda_p-5$ (*2)	$\lambda_p$ (*1)	$\lambda_p+5$ (*2)	nm
Spectral Linewidth (FWHM)	$\Delta\lambda$	CW, $P_f=10$ mW	-	2(*3)	-	MHz
Temperature Coefficient of $\lambda_p$	$d\lambda_p/dT$	CW	-	0.08	-	nm/K
Current Coefficient of $\lambda_p$	$d\lambda_p/dI$	CW	-	0.008	-	nm/mA
Fiber Output Power	$P_f$	CW	10	-	-	mW
Threshold Current	$I_{th}$	CW	-	15	-	mA
Operation Current	$I_{op}$	CW, $P_f=10$ mW	-	50	80	mA
Operation Voltage	$V_{op}$	CW, $P_f=10$ mW	-	1.4	1.8	V
Sidemode Suppression Ratio	SMSR	CW, $P_f=10$ mW	-	40	-	dB
Polarization Extinction Ratio	PER	CW	15	20	-	dB
Monitor PD Current	$I_m$	CW, $P_f=10$ mW	10	100	1000	$\mu\text{A}$
Thermistor Resistance	$R_{th}$	$T_{LD} = 25^{\circ}\text{C}$ , $B=3900\text{K}$	9.5	10	10.5	k $\Omega$

(\*1) Available peak wavelength is from 1018 to 1122 nm and 1140 to 1188 nm.

(\*2) Tighter wavelength tolerance of +/- 1 nm and +/- 0.5 nm is available as an option. Refer to product part number according to wavelength tolerance

(\*3) QD Laser, Inc. does not guarantee the linewidth of an individual diode.

**5-2. 30 mW verison: QLD1a61-xx30CzWtt**

 ( $T_{LD} = 25^{\circ}\text{C}$ , unless otherwise specified)

PARAMETER	SYMBOL	TEST CONDITION	MIN	TYP	MAX	UNIT
Peak Wavelength	$\lambda_p$	CW, $P_f=30$ mW	$\lambda_p-5$ (*2)	$\lambda_p$ (*1)	$\lambda_p+5$ (*2)	nm
Spectral Linewidth (FWHM)	$\Delta\lambda$	CW, $P_f=30$ mW	-	2(*3)	-	MHz
Temperature Coefficient of $\lambda_p$	$d\lambda_p/dT$	CW	-	0.08	-	nm/K
Current Coefficient of $\lambda_p$	$d\lambda_p/dI$	CW	-	0.008	-	nm/mA
Fiber Output Power	$P_f$	CW	30	-	-	mW
Threshold Current	$I_{th}$	CW	-	20	-	mA
Operation Current	$I_{op}$	CW, $P_f=30$ mW	-	150	200	mA
Operation Voltage	$V_{op}$	CW, $P_f=30$ mW	-	1.7	2.0	V
Sidemode Suppression Ratio	SMSR	CW, $P_f=30$ mW	-	40	-	dB
Polarization Extinction Ratio	PER	CW, $P_f=30$ mW	15	20	-	dB
Monitor PD Current	$I_m$	CW, $P_f=30$ mW	50	200	1,000	$\mu\text{A}$
Thermistor Resistance	$R_{th}$	$T_{LD} = 25^{\circ}\text{C}$ , $B=3900$ K	9.5	10	10.5	k $\Omega$

(\*1) Available peak wavelength is from 1018 to 1122 nm and 1140 to 1188 nm.

(\*2) Tighter wavelength tolerance of +/- 1 nm and +/- 0.5 nm is available as an option. Refer to product part number according to wavelength tolerance

(\*3) QD Laser, Inc. does not guarantee the linewidth of an individual diode.

## 6. PRODUCT PART NUMBER

### 6-1 General naming rule

QLD1a61-xyyCzWtt

Symbol	Item	Condition	Parameter
a	Main wavelength range	1axx defines wavelength range in nm	a=0: 10xx nm range a=1: 11xx nm range
xx	Main wavelength range	xx defines the last two digits of the wavelength range in nm	xx=30: 1030 nm range xx=53: 1053 nm range xx=64: 1064 nm range xx=83: 1083 nm range (examples)
yy	Output power	Minimum output power	yy=10: 10 mW yy=30: 30 mW
tt	Wavelength	Detailed specification of wavelength	xx=63: 1063 nm xx=32: 1032 nm (examples)
zW	Wavelength tolerance	wavelength tolerance	none: +/-5 nm W: +/-1 nm TW: +/-0.5 nm

### 6-2 Connector type

Part Number	Fiber Type	Fiber Diameter	Connector
QLD1a61-xyyCzWtt	Polarization maintaining fiber	900 $\mu$ m	FC/APC
QLD1a61-xyyCzWtt11		250 $\mu$ m	Ferrule/APC

### 6-3 Examples of product part number

Examples of product name	
Part Number	Peak Wavelength (nm)
QLD1061-6410CW60	1060 nm +/-1 nm, 10 mW 900 $\mu$ m Fiber
QLD1061-3030CTW3211	1032 nm +/-0.5 nm, 30 mW 250 $\mu$ m Fiber
QLD1161-2230CW2211	1122 nm +/-1 nm, 30 mW 250 $\mu$ m Fiber
QLD1061-8330C	1083 nm +/-5 nm, 30 mW 900 $\mu$ m Fiber

7. OUTLINE DRAWING

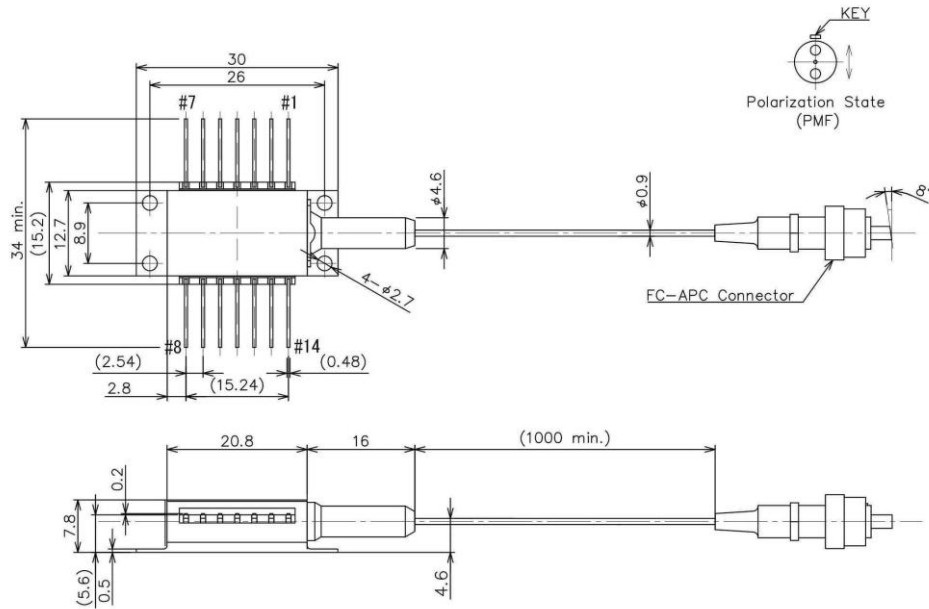

(a) 900 μm fiber diameter and FC/APC connector type (QLD1a61-xyyCzWtt)

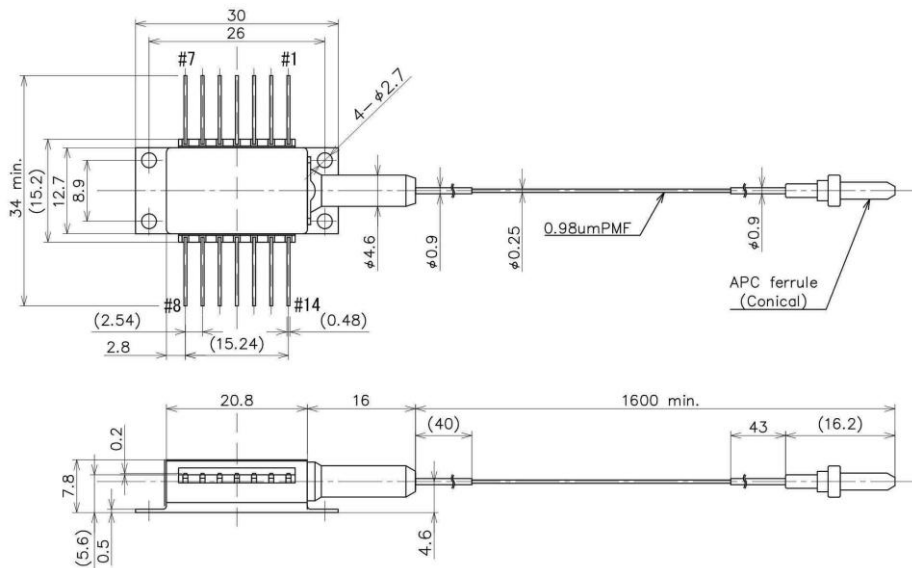

(b) 250 μm fiber diameter and ferrule type (QLD1a61-xyyCzWtt11)

## 8. PIN CONFIGURATION

No.	Description	No.	Description
1	TEC (+)	8	NC
2	Thermistor	9	NC
3	PD Anode	10	Laser Anode
4	PD Cathode	11	Laser Cathode
5	Thermistor	12	NC
6	NC	13	Case Ground
7	NC	14	TEC (-)

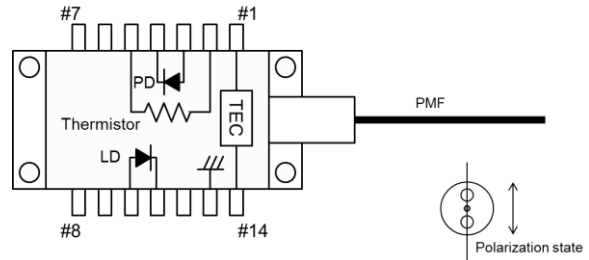

## 9. NOTICE

- Safety Information

This product is classified as Class 3B laser product, and complies with 21 CFR Part 1040.10. Please do not take a look at laser lighting in operations since laser devices may cause troubles to human eyes. Please do not eat, burn, break and make chemical process of the products since they contain GaAs material.

- Handling products

Semiconductor lasers are easily damaged by external stress such as excess temperature and ESD. Please pay attention to handling products, and use within range of maximum ratings. QD Laser takes no responsibility for any failure or unusual operation resulting from improper handling, or unusual physical or electrical stress.

- RoHS

This product conforms to RoHS compliance related Directive (EU) 2015/863.



**DANGER**

INVISIBLE LASER RADIATION  
AVOID DIRECTION EXPOSURE TO BEAM

MAXIMUM OUTPUT 300 mW  
WAVELENGTH 1000~1200 nm  
CLASS 3B LASER PRODUCT

LASER DIODE

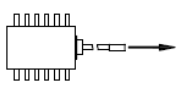

AVOID EXPOSURE-Invisible Laser Radiation is emitted from this aperture.

This product complies with 21 CFR Part 1040.10

**QD Laser, Inc.**

1-1 Minamiwataridacho, Kawasaki-ku, Kawasaki, Kanagawa, 210-0855 Japan

QD Laser, Inc.

Contact : [sales@qdlaser.com](mailto:sales@qdlaser.com) <https://www.qdlaser.com>

Copyright 2022-2025 All Rights Reserved by QD Laser, Inc.

Keihin Bldg. 1F 1-1 Minamiwatarida-cho, Kawasaki-ku, Kawasaki, Kanagawa Zip 210-0855 Japan

All company or product names mentioned herein are trademarks or registered trademarks of their respective owners. Information provided in this data sheet is accurate at time of publication and is subject to change without advance notice.