

QC4LD0593 series

Ultra-compact light source for plug-and-play

Preliminary

C00301-01 May 2025



1. DESCRIPTION

QC4LD0593-xxxx, Lantana™, is an ultra-compact light source with integrated driver and is a plug-and-play unit via USB communication.

2. FEATURES

- Compact plug-and-play driver-integrated unit.
- Patented high stability single frequency laser combining DFB laser and second harmonic generation.
- Unprecedented compact unit 38 x 62 x t22.7 mm (53 cc).
- CW/Modulation light source controlled via serial communication.

3. APPLICATION

- Flow Cytometry
- Cell Sorting
- Laser Microscopy
- Raman Spectroscopy

4. SPECIFICATIONS

(Ambient temp. = 25°C)

Model Number	QC4LD0593-32xx	QC4LD0593-61xx	QC4LD0593-94xx
Peak Wavelength	532 +/- 1 nm	561 +/- 1 nm	594 +/- 1 nm
Output Power	xx = 20 : 20 mW xx = 30 : 30 mW xx = 50 : 50 mW	xx = 20 : 20 mW xx = 30 : 30 mW xx = 50 : 50 mW	xx = 05 : 5 mW
Maximum Output Power	xx = 20 : 25 mW xx = 30 : 40 mW xx = 50 : 60 mW	xx = 20 : 25 mW xx = 30 : 40 mW xx = 50 : 60 mW	xx = 05 : 8 mW
Beam Diameter	Horizontal 0.5 mm x Vertical 1.1 mm at 1/e ² (Typ.)		
Beam Divergency (Full Angle)	1.2 mrad at 1/e ² (Typ.)		
Beam Angle	< 2.5 mrad		
Power Stability	< 2% (under CW mode, 8 hrs)		
RMS Noise	< 1% at 120 kHz to 10 MHz (under CW mode)		
Polarization Ratio	> 12 dB		
Polarization Direction	Horizontal		
Digital Modulation Bandwidth	0 – 50 kHz		
Rise Time / Fall Time	< 5 μsec / < 3 μsec		

Model Number	QC4LD0593-32xx	QC4LD0593-61xx	QC4LD0593-94xx
Dimension	38 x 62 x t22.7 mm		
Weight	157 g		
External Clock & Sync Out Voltage	3.3 V CMOS level		
Serial Communication	Lantana side : USB Type-C, PC side : USB Type-A		
AC Power Adapter	AC input voltage : 100~240 V - DC output voltage : 12 V		
Ambient Temperature	15 – 37°C		
Ambient Humidity	< 65%RH		
Power Consumption	2.2 W at 50 mW (Typ.)		

5. OUTLINE DRAWING

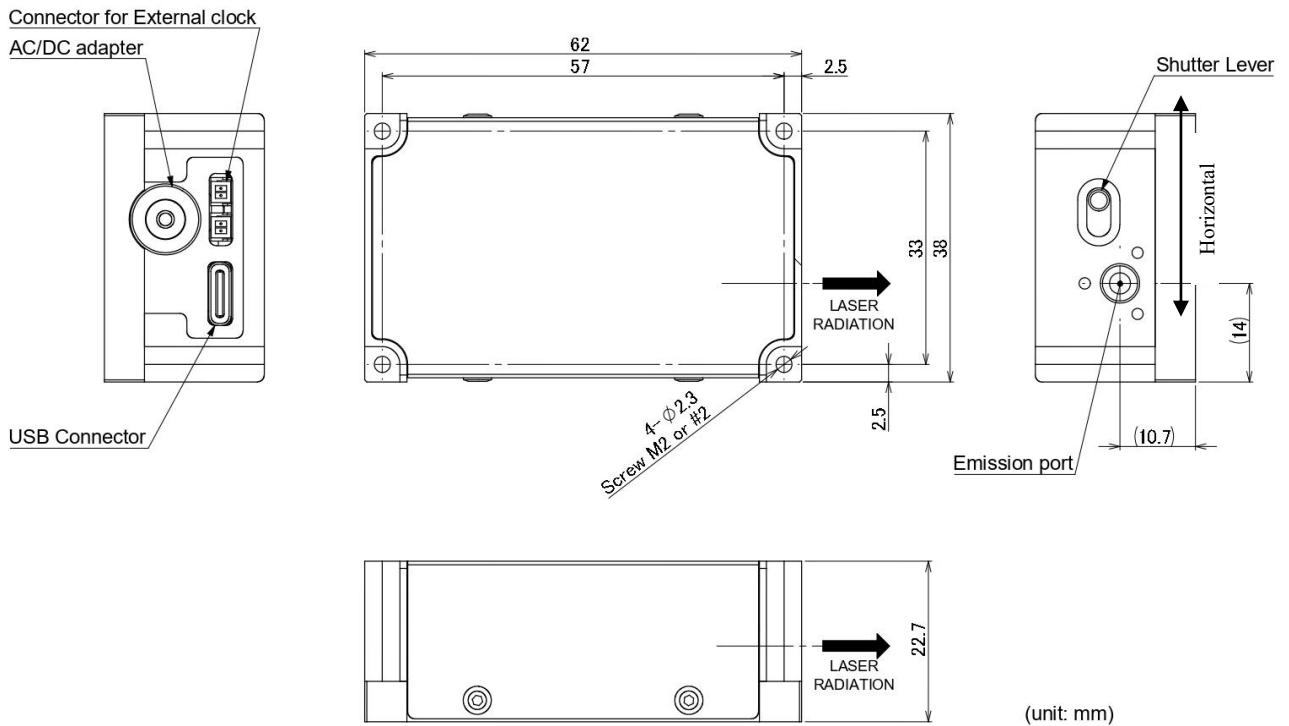

6. SETUP

- Be sure to fix Lantana™ to heatsink before operation.
- Do not apply thermal grease between the heatsink and Lantana™.
- The mounting surface should be flat, within < 0.05 mm.
- Fixing screw size is 4-M2x8 or 4-#2x5/16.
- Lantana will overheat and shut down if it is not adequately heatsinked.
- The figure below shows the needed thermal impedance of heatsink.

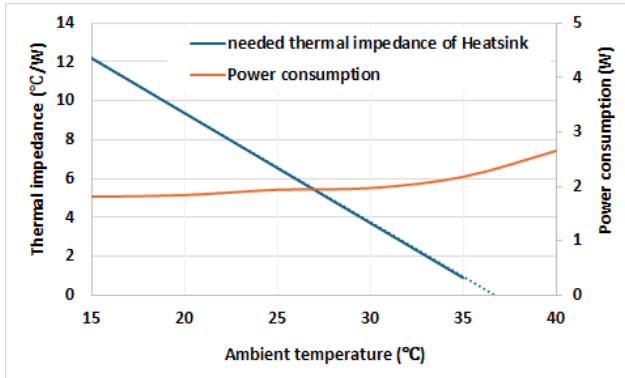

7. NOTICE

- Safety Information

This product is classified as Class 3B laser product, and complies with 21 CFR Part 1040.10.

Please do not take a look at laser lighting in operations since laser devices may cause troubles to human eyes.

Please do not eat, burn, break and make chemical process of the products since they contain GaAs material.

- Handling products

Semiconductor lasers are easily damaged by external stress such as excess temperature and ESD.

Please pay attention to handling products, and use within range of maximum ratings.

QD Laser takes no responsibility for any failure or unusual operation resulting from improper handling, or unusual physical or electrical stress.

- RoHS

This product conforms to RoHS compliance related Directive (EU) 2015/863.

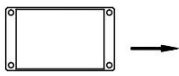
 <p>DANGER</p> <p>VISIBLE AND/OR INVISIBLE LASER RADIATION AVOID DIRECTION EXPOSURE TO BEAM</p> <p>MAXIMUM OUTPUT 300 mW WAVELENGTH 400~1000 nm CLASS III B LASER PRODUCT</p>	<p>LASER DIODE</p>  <p>AVOID EXPOSURE Laser Radiation is emitted from this aperture.</p>
<p>This product complies with 21 CFR Part 1040.10 and 1040.11 except for deviations pursuant to Laser Notice No.50, dated June 24, 2007</p> <p>QD Laser, Inc.</p> <p>1-1 Minamiwataridacho, Kawasaki-ku, Kawasaki, Kanagawa, 210-0855 Japan</p>	



QD Laser, Inc.

Contact : sales@qdlaser.com <https://www.qdl-laser.com>

Copyright 2025 All Rights Reserved by QD Laser, Inc.

Keihin Bldg. 1F 1-1 Minamiwatarida-cho, Kawasaki-ku, Kawasaki, Kanagawa Zip 210-0855 Japan

All company or product names mentioned herein are trademarks or registered trademarks of their respective owners. Information provided in this data sheet is accurate at time of publication and is subject to change without advance notice.