

QBBM402

Driver box for Multi-color compact laser light source

Preliminary

C00259-04 December 2021



1. DESCRIPTION

The QBBM402 is a driver box for Multi-color compact laser light source of QLM4xx series. This driver can control laser output power, module temperature under CW/pulse operation controlled by PC software via USB interface. Only single +12V power supply is required for the board operation.

2. FEATURES

- Designed for Multi-color compact laser light source of QLM4xx series
- USB interface allows to set the laser power, modulation sequence and temperature using PC software
- CW and pulsed operation
- APC/ACC control available
- Equipped with the dedicated driver and DFB optimization sequence for visible compact module

3. APPLICATION

- Fluorescence microscope
- Spectroscopy
- Biomedical applications

4. FUNCTION BLOCK DIAGRAM

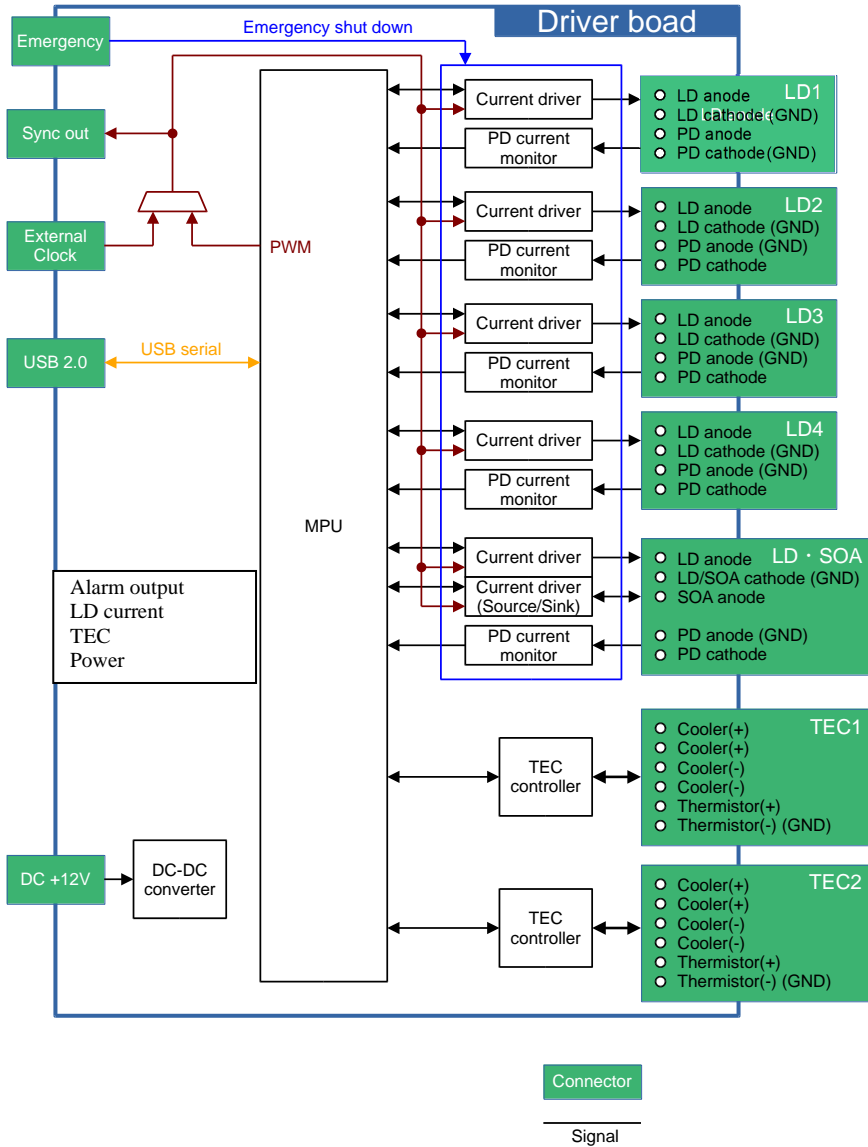

5. ABSOLUTE MAXIMUM RATINGS

 ($T_c = 25^\circ\text{C}$, unless otherwise specified)

PARAMETER	SYMBOL	RATING	UNIT
Operation Temperature	T_c	20 to 30	$^\circ\text{C}$
Storage Temperature	T_{stg}	-10 to 50	$^\circ\text{C}$
Storage Relative Humidity	RH	< 90 (no condensation)	%

6. SPECIFICATIONS

6-1. Specifications of LD1 to LD4

 ($T_c = 25^\circ\text{C}$, unless otherwise specified)

#	Item	Unit	LD1	LD2 #1	LD3	LD4	Remark
1	Types of LD	nm	488	(515)	660	785	#1
2	Maximum LD current	mA	200	300	200	200	
3	Resolution of LD current	mA	> 0.05	> 0.05	> 0.05	> 0.05	
4	Maximum LD voltage	V	6.2	7.5	3.0		
5	Modulation frequency	kHz	< =100		< = 100		Target value, #2
6	Pulse width	μs	> = 5		> = 5		
7	Tr/Tf (10-90%)	μs	< 5		< 5		Target value

#1: LD2 is not available for this driver box.

6-2. Specifications of DFB-SOA

DFB-SOA is for compact visible laser operation.

 ($T_c = 25^\circ\text{C}$, unless otherwise specified)

#	Item	Unit	LD	SOA	Remark
1	Maximum LD current	mA	300	500	
2	Resolution of LD current	mA	0.08	0.2	
3	Maximum LD voltage	V	4.0		
4	Modulation frequency	kHz	N/A	< = 100	Target value, #2
5	Pulse width	μs	N/A	> = 5	
6	Tr/Tf (10-90%)	μs	N/A	< 5	Target value

#1: Wavelength combination is an example. LD1 and LD2 are for lasers to operate high voltage for GaN systems. LD3 and LD4 are for lasers for GaAs systems.

#2: Minimum modulation frequency under internal trigger is 100Hz.

6-3. Specifications of TEC1 and 2

#	Item	Unit	TEC1	TEC2 #2	Remark
1	Operation temperature	°C	20-30		
2	Resolution of temperature	°C	<= 1		
3	Maximum TEC voltage	V	4.5		
4	Maximum TEC current	A	1.5		
5	Temperature stability	°C	±0.05		Target value

#2: TEC2 is not available for this driver box.

6-4. Other Specifications

6-4-1. Input of External Clock

Input of external clock is 3.3V CMOS level. High or 50 Ω can be selected as input impedance by connection of jumper pin on circuit. Input signal is used as trigger of pulse width modulation for lasers, and duty of input signal is used as duty of pulse width modulation.

6-4-2. Output of Sync Out

Output of sync out is 3.3V CMOS level, and output of low impedance. It is output as the waveform copy of duty of pulse width modulation.

6-4-3. USB 2.0

USB 2.0 is a serial port for the connection of PC.

6-4-4. DC Input Voltage

DC input voltage is + 12 V, and acceptable tolerance is + 12 V +/- 10%. The power consumption is T.B.D.

6-4-5. Emergency Shut Down

Emergency shut down can turn off drivers without control of CPU.

7. MPU FIRMWARE FUNCTION

7-1. Auto current control and auto power control

Current driver provides ACC function, and parameters are set by the firmware. The procedure of APC is to tune ACC value to eliminate the difference between target value and PD monitor value measured by the firmware. The purpose of APC control is mainly the correction of optical output power by changing ambient temperature, and the interval of updating data is less than 100 ms (target: 10ms).

The following notes should be considered.

ACC/APC mode can be separately selected for each lasers. Lasers must be off when modes are changed.

Pulse mode operation is not available under APC operation,

APC value can be set to be 10 to 110% when typical APC output is defined as 100%.

The power monitor range is 0 to 400% (design value.)

7-2. Temperature setting of TEC controller

Target temperature of TEC controller is set by firmware. The default value is 25 °C.

7-3. Alarm function

The following parameters are monitored by firmware. The monitoring period is less than 1s. Alarm signals are LED on the board.

7-3-1. Abnormal of LD current

The alarm is generated when 25% is changed to the initial value of LD current under APC operation.

7-3-2. Abnormal temperature

The alarm is generated when the difference between real and setting temperatures is +/- 1 °C. This alarm is always generated when the driver turns on.

7-3-3. Abnormal power supply

The alarm is generated when the difference of power supply is +/- 2V compared to 12 V.

8. EXTERNAL DIMENSIONS AND FUNCTIONS OF FRONT AND REAR PANELS

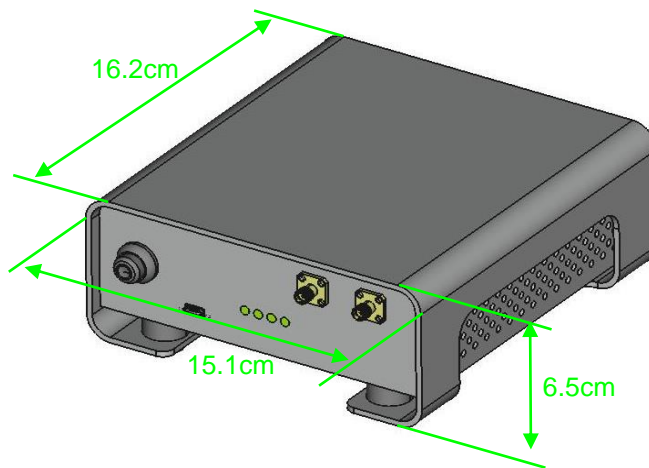

Front side

Rear side

DC+12V input

Power switch On/Off (and emergency switch)

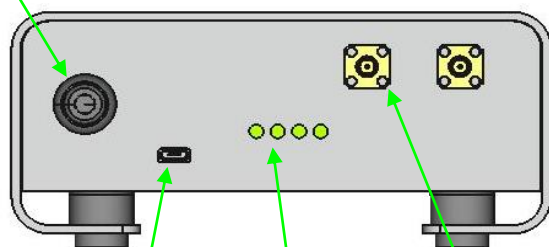

USB connector

Input of External Clock and Output of Sync Out

LED of status display

POW ERR TEC1 TEC2

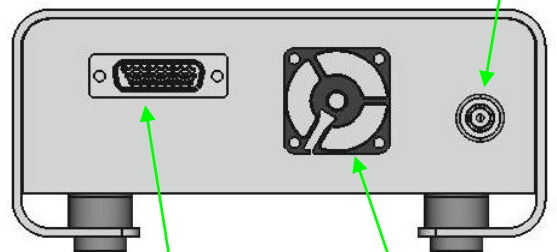

26 pin D-sub connector, female

Cooling fan

9. PIN ASSIGNMENT OF ELECTRICAL CONNECTOR

Electrical connector: D-subminiature, 26pin, female

Pin No.	Function		Pin No.	Function	
1	488nm	LD Anode	19	WDM module Thermistor(+)	
2		LD Cathode	20	WDM module Thermistor(-)	
3		PD Anode	21	Peltier cooler(+)	
4		PD Cathode (CASE GND)	22	Peltier cooler(+)	
5	660nm	LD Anode	23	Peltier cooler(+)	
6		Short Circuit (CASE GND)	LD Cathode	24	Peltier cooler(-)
7			PD Anode	25	Peltier cooler(-)
8		PD Cathode	26	Peltier cooler(-)	
9	NC				
10	785nm	LD Anode			
11		Short Circuit (CASE GND)	LD Cathode		
12			PD Anode		
13		PD Cathode			
14	532nm	Common Cathode (DFB, SOA)			
15		DFB Anode			
16		SOA Anode			
17		PD Anode			
18		PD Cathode			

10. ACCESSORIES

D-sub connector cable, 50cm

USB cable to PC, 1m

AC adapter with cable

11. NOTICE

- Handling products

Stresses at or above those listed under Absolute Maximum Ratings, and ESD may cause permanent damage to the product. Please pay attention to handling products, and use within range of maximum ratings.

QD Laser takes no responsibility for any failure or unusual operation resulting from improper handling, or unusual physical or electrical stress.

- RoHS

This product conforms to RoHS compliance related Directive (EU) 2015/863.

QD Laser, Inc.

Contact : info@qdlaser.com <http://www.qdlaser.com>

Copyright 2021 All Rights Reserved by QD Laser, Inc.

Address : Keihin Bldg. 1F 1-1 Minamiwataridacho, Kawasaki-ku, Kawasaki, Kanagawa Zip 210-0855 Japan

All company or product names mentioned herein are trademarks or registered trademarks of their respective owners. Information provided in this data sheet is accurate at time of publication and is subject to change without advance notice.

