

OtO Photonics

SideWinder™ Series

Product sheet



Description

SW series spectrometers combine standard (900-1700nm) or extended-response (910-2200nm and 900-2500nm) InGaAs linear sensors and a high performance 32-bit RISC controller in an optimized Czerny-Turner cavity.

SideWinder's compact and rigid package provides a stable measurement platform offering excellent thermal and humidity cycling performance together with minimum variation of resolution and wavelength shift due to shock and vibration.

SW 5 Series : SW25X0 (900-1700nm)

SW 8 Series : TECooling version SW28X0 (900-1700nm)

SW 9 Series : TECooling version SW29X0 (910-2200 or 900-2500nm)

PC communication and power interface with the SW series is via USB with an additional 6 I/Os for external connections.

The SW series 32-bit RISC controller can be addressed using OtO Photonics' fully-featured spectral measurement software "SpectraSmart " which includes Windows SDK and other example code.



This document is intended for sales and marketing purposes only and may not serve as a specification document for shipping or contracts. If a specification for product approval or IQC is required please contact OtO or your distributor.

SW Series-412 Rev.2
www.otophotonics.com

OtO Photonics

SW Series Product sheet

Attention

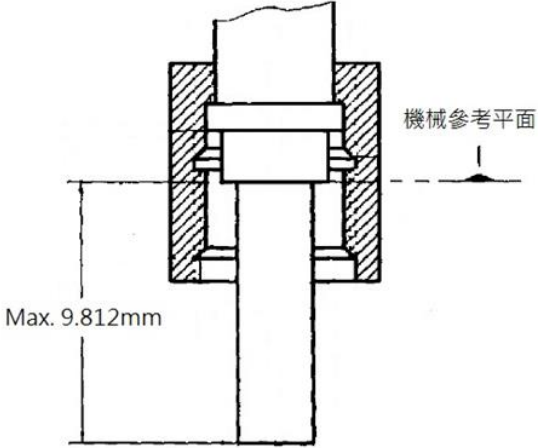
#	Picture	Description
1		<p>Screw in the fiber optic connector with fingers. Do not use any tool to tighten it. Using tools such as wrenches to tighten the connector may cause the connector to press against and damage the inlet slit of the spectrometer. Such damage is not covered by the warranty.</p> <p>In cases where the connector needs to be firmly in place for long-term use, it is advised to apply a little glue to where the SMA905 connector is connected to the spectrometer.</p>
2		<p>The SMA905 connectors on all spectrometers made by OtO Photonics is manufactured in accordance with international standards. Customers should ensure that the ferrule length of the fiber used is not longer than 9.812mm to avoid damaging the slit in the SMA950 connector. Such damage is not covered by the warranty.</p>
3		<p>According to the notification from Hamamatsu Photonics, there will be 0~5% defect pixels in the linear image sensor. On the defect pixel, spectral response is non-uniformity and readout noise or dark current is out of the specification. Once we found the defect pixels, we will inform customer before product shipping and disable defect pixels via our software (resolution reduce), and OtO will provide technical advisory service.</p> <p>Defect Pixel≤1% : SE2560, SW2570, SW2860, SW2870 Defect Pixel≤2% : SW2520 Defect Pixel≤5% : SW2930、SW2960、SW2970</p>

OtO Photonics

SW Series Product sheet

■ Overview

1.1 Lineup of SW Series / Grating Table and Resolution P4

1.2 Efficiency output , Base line, Dark Noise, Dynamic range, resolution P5

1.3 Dark Output Voltage & Dark Current caused by the Sensor of SW2970 and the different between Even Pixels and Odd Pixels P8

■ Main Features

2.1 Feature P9

2.2 Specification P10

■ Structure

3.1 Mechanical Diagram P13

3.2 Electrical Pinout P16

3.3 Detector Overview P18

■ Internal Operation P21

■ USB Port Interface Communications and Control Information P23

OtO Photonics

SW Series Product sheet

Overview

1.1 Lineup of SW Series

Model		Wavelength Range (nm)			Sensor type	SNR ^{*1} (Single acquisition)		Dynamic Range ^{*2}		A/D	Stray Light ^{*4} (%)	Thermal Stability (nm/°C)			
		900	910	900		High Gain	Low Gain	High Gain	Low Gain						
		∞	∞	∞											
		1700	2200	2500											
SW 5 Series	SW2520	√			InGaAs Sensor	2000	4000	6500	8200	16 bits	<0.2	<0.1			
	SW2560	√				2400	4500	6000	9300						
	SW2570	√				2500	4000								
SW 8 Series	SW2860	√			InGaAs TEC Sensor	3200	4500	8000	13000	16 bits	<0.2	<0.1			
	SW2870	√				3200	4500	7200	9300						
SW 9 Series	SW2930		√			2800	5300	6000	9300				<0.45	<0.2	<0.1
	SW2960 ^{*3}			√		2500	4500	7000	12000						
	SW2970			√	2500	4500	6000	9300							

*1 : The value of SNR & Dynamic Range on the table above are obtained under microsecond or millisecond level of integration time. (Measurement Condition : TECooled @ 0 ° C)

*2 : The performance of TECooling will be more obvious under long integration time. (SW2960/SW2970 Measurement Condition : Integration Time 100us, Sensor TECooled @ -20 ° C) DynamicRange=65535/Average Dark Noise & (65535/up limit Dark Noise)

*3 : Due to the characteristic of the Sensor of SW2960, the performance of SNR and recommend integration time are both different with SW2860 or SW25X0.

*4 : Stray light <0.2%, <0.45% at 1000nm, detected with FEL1300 longpass filter.

	Dark Background	
	avg. counts @1sec	avg. counts @10sec
SW 8 Series	1000	1500
SW 5 Series	2000	4500

*Lower Background is better.

- As the table above, the Dark Background of SW 8 are obviously better than SW 5 under long integration time.

OtO Photonics

SW Series Product sheet

► 1.2 Efficiency Output, Base line, Dark Noise, Dynamic range, Resolution

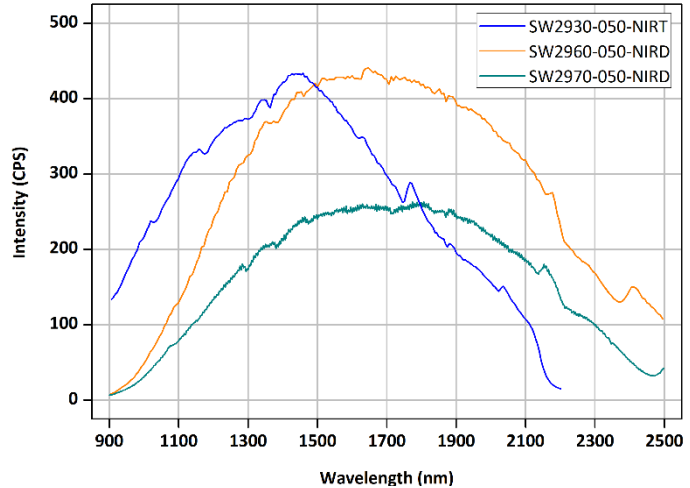
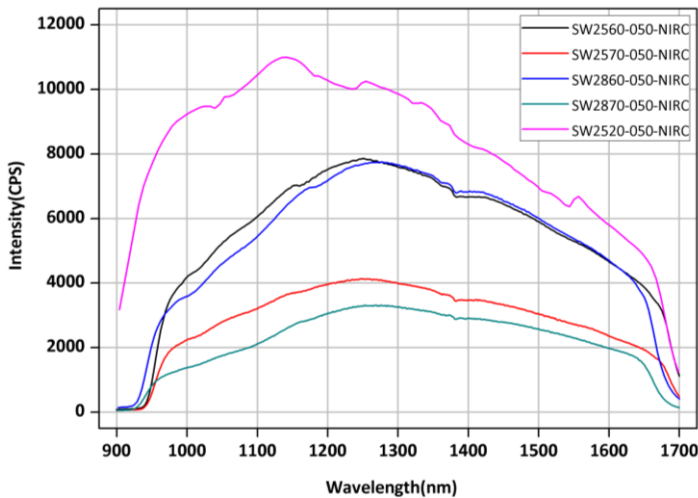

High Gain vs Low Gain Comparison

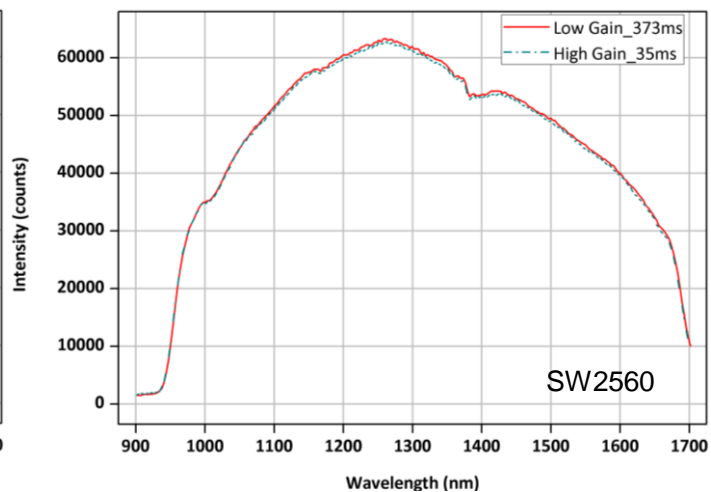
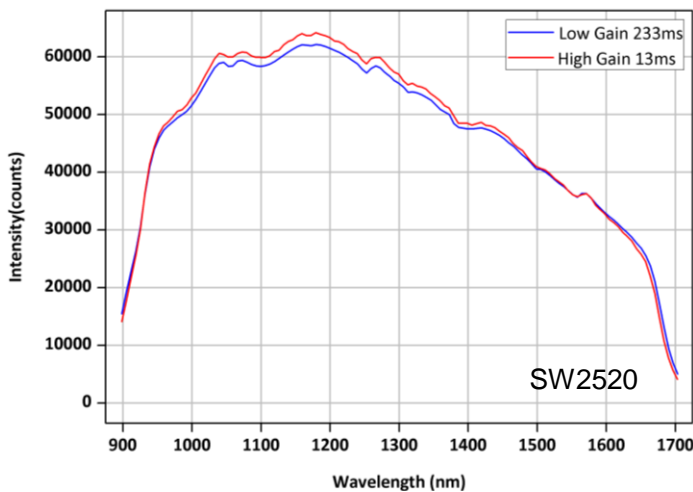

● SW series provide two different sensitivity modes for customers to choose from: (High Gain) and (Low Gain). As shown above, the average sensitivity of High Gain mode is about 18 times (SW2520) / 10 times (SW2560) greater than counterpart of Low Gain mode, but SNR and dynamic range values are also adjusted in two different modes. Please refer to the chart in P4 1.1-1 ,SW series. In the High Gain mode, the maximum integration time we suggest customers to set up is 500ms. If customers did not specify when placing orders, the gain mode is preset to low gain mode when SW series are shipped.

OtO Photonics

SW Series Product sheet

SW2860 Waveform Cooling vs. Non-Cooling

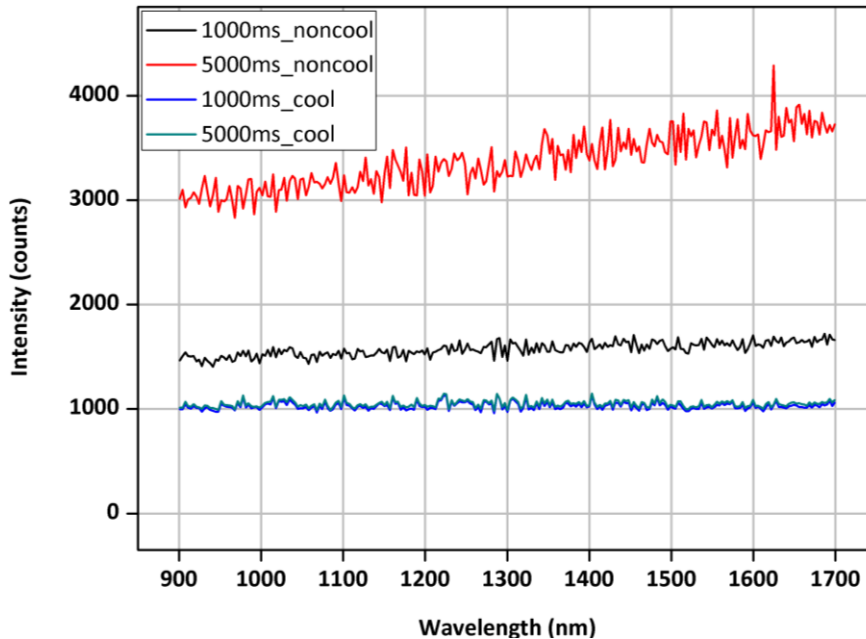

- With TECooling, the noise resulted from long integration times can be significantly reduced and it result in smooth and normalized waveform. The Dark Noise decreased from >15000 count & >5000 count to 2000 count & 1000 count under integration time 1000ms & 5000ms.

OtO Photonics

SW Series Product sheet

Base line, Dark Noise, Dynamic range, Resolution Of SW2930 & SW2960

Base line
SW2930 VS SW2960

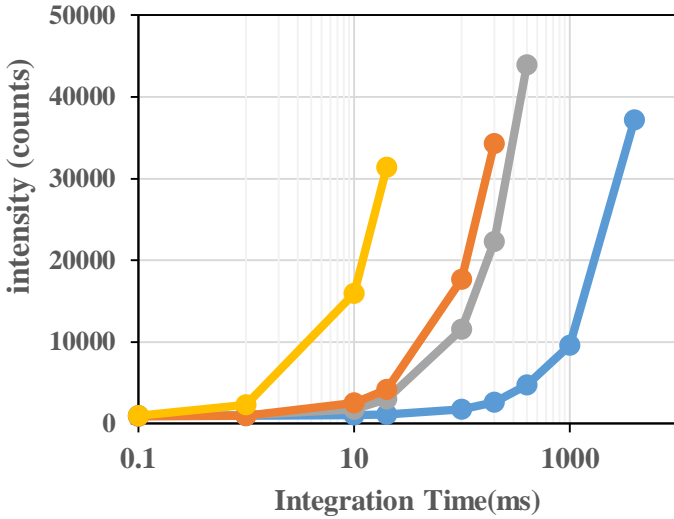

Dark noise
SW2930 VS SW2960

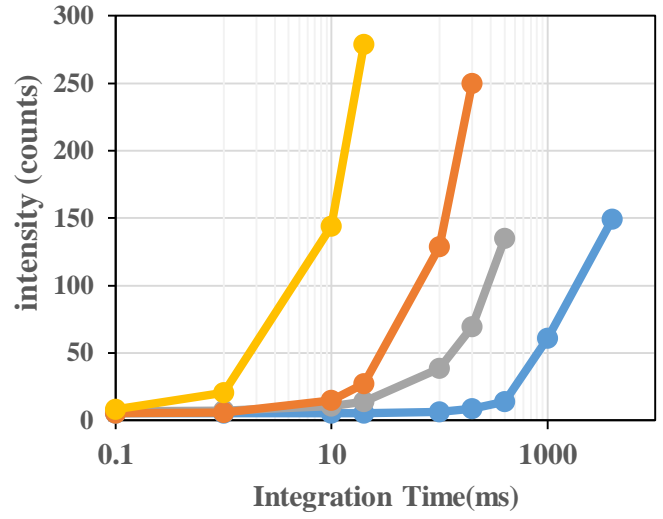

Dynamic range
SW2930 VS SW2960

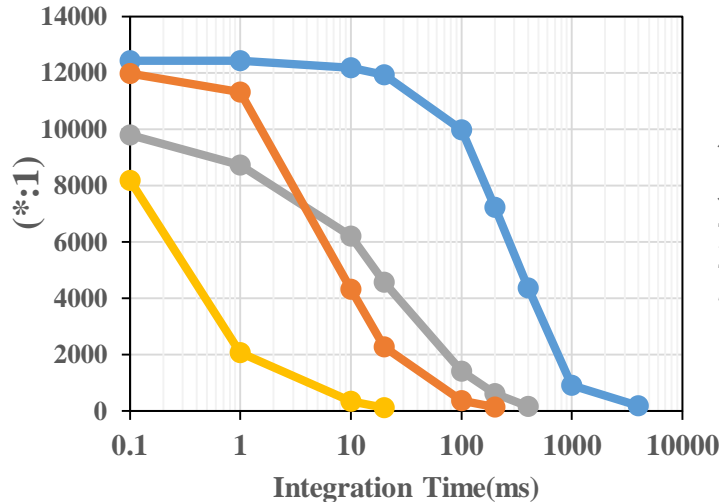

Resolution
SW2930 VS SW2960

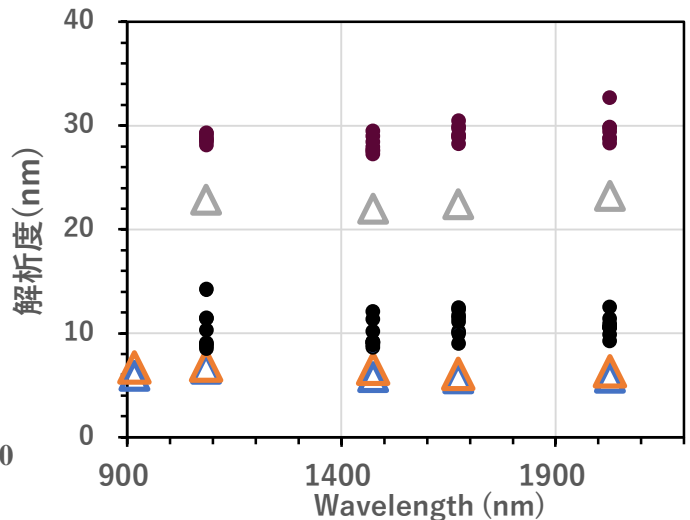

- SW2930 Low gain ● SW2930 High gain ● SW2960 Low gain ● SW2960 High gain
- ▲ SW2930(Slit 25um)30307 ▲ SW2930(Slit 50um)30336 ▲ SW2930(Slit 200um)30337

- SW2930 has a wavelength range of 910-2200nm, which is shorter compared to SW2960 with a range of 900-2500nm. However, the SW2930 shows improvements in baseline, dark noise, dynamic range, and resolution compared to the SW2960.

OtO Photonics

SW Series Product sheet

► 1.3 Dark Output Voltage & Dark Current caused by the Sensor of SW2970 and the different between Even Pixels and Odd Pixels.

Dark Output Voltage/Current Spec. of SW2970 Sensor

SW2970 Sensor Parameter	Min	Typical	Max	Unit
Dark Output (Dark Output non-uniformity)	-100	±10	100	V/s
Dark Current	-1000	±100	1000	pA

As shown in the table above and the picture A & B below (provided by Hamamatsu), the range of Dark Output Voltage/Current is very wide. Apart from this, as shown in the picture C, there are two video_out pin (Video_even and Video Odd) on the sensor, it may result in significant differences between the baseline of even pixels and odd pixels.

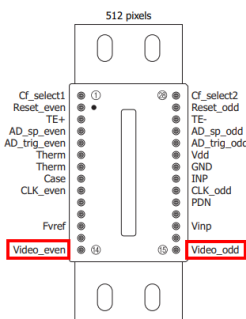
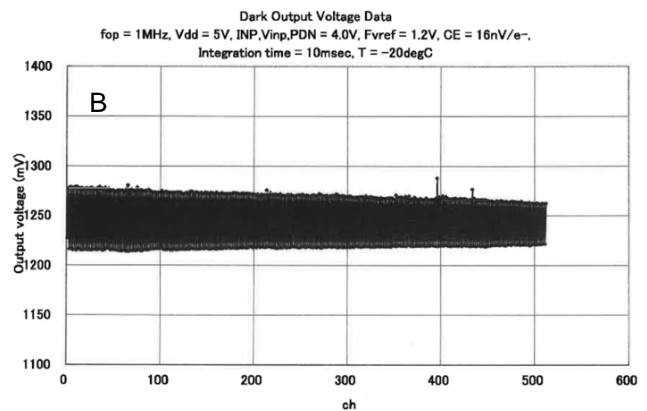
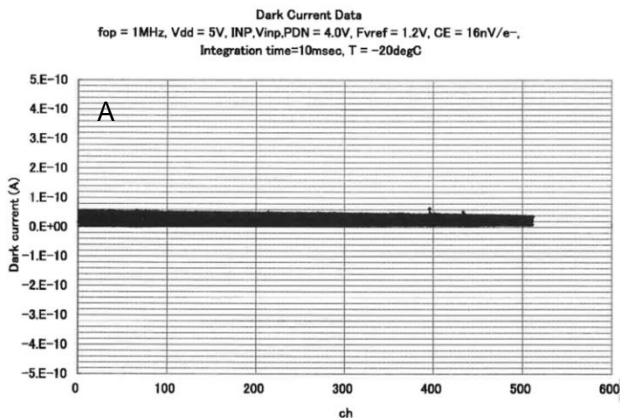

Picture C. SW2970 sensor Pin Connection

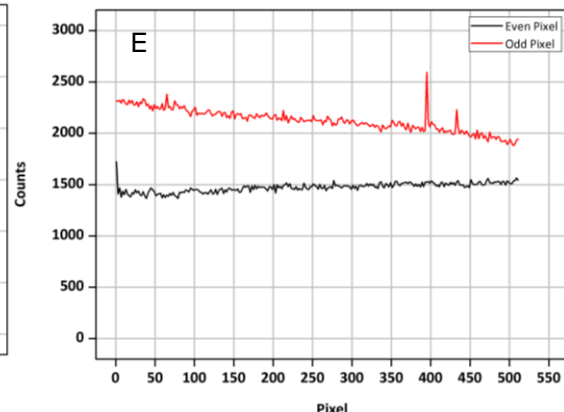
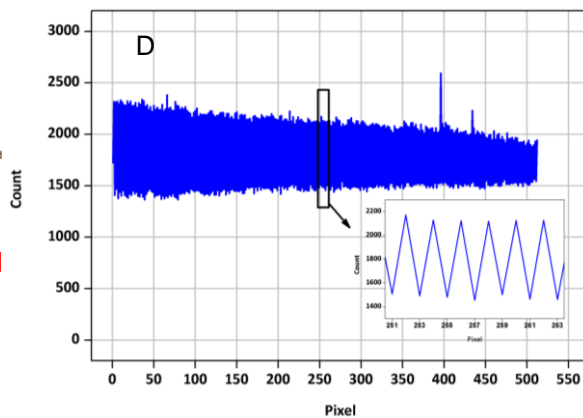

SW2970 Baseline Differences Between Even Pixels and Odd Pixels

Due to it has two video out pin (one for even pixels & another is for odd pixels), the phenomenon remain after assembled the sensor in SW2970, as shown in picture D. In picture D, the curve seems keep rise and fall, but when we divide signals between Even Pixels & Odd Pixels, it can be found the signal split into 2 groups (Even pixels & odd pixels), as shown in picture E. That difference of Even Pixels and Odd Pixels, can be remove by dark noise defecation before measurement.

■ Main Features

▶ 2.1 Feature

- Responsive wavelength range :
SW 5 & 8 Series (SW25X0 、 SW2860)_900~1700 nm
SW 9 Series (SW2960 、 SW2970)_900~2500 nm
- Optical resolution: from 2 to 22 nm, depending on the combination of various slits, sensors and gratings.
- A variety of sensor can be chosen for specific application:
 - High SNR and high sensitivity 128-pixel InGaAs linear sensor
 - High SNR and high sensitivity 256-pixel InGaAs linear sensor
 - High SNR and high sensitivity 512-pixel InGaAs linear sensor
- Modular configuration with various grating, sensor, and slit options
- Integration times of SW 5 & 8 series are from 100 μ s to 24 sec, SW 9 series is from 100 μ s to 3000ms or 200ms.
- 16 bit, 15MHz A/D Converter
- USB 2.0 @ 480 Mbps (High speed)
- 8-pin connector for interfacing to external
 - 6 user programmable digital I/O
- Plug-n-play interface for PC application
- Extremely precise continuous multiple exposures, providing up to 4,000 spectra buffering
- Flash ROM storage for
 - Wavelength Calibration Coefficients
 - Linearity Correction Coefficients
 - Intensity calibration coefficients
- TECooling
 - One Stage TEC: Default : 0 ° C at Ambient of 25 ° C
 - Two Stage TEC: Default : -20 ° C at Ambient of 25 ° C

OtO Photonics

SW Series Product sheet

► 2.2 Specification

Specification		Value		
		SW2520	SW2560	SW2570
Sensor		128Pixel	256Pixel	512Pixel
		None-Cooling		
Spectrometer		SW series; Czerny-Turner Optical Layout, 2nd & 3rd order elimination		
Dimension		110(L) x 86(W) x 32.4(H) mm		
Parameters of Optical System		f/# : 5, NA :0.1, Focal Length(R1-R2) :60-60 (It is recommended that the Incident NA should larger than the NA of spectrometer.)		
Wavelength		900-1700 nm		
Slit (um)		50/100/150	50/100/ 150/200	25/50/100/150/200
Integration time	High Gain	100μs ~ 24sec, depending on sensors		
	Low Gain			
Dark Noise (average)	High Gain	10	11	11
	Low Gain	8	7	8
SNR (Single acquisition)	High Gain	2000	2400	2500
	Low Gain	4000	4500	4000
Dynamic range (avg.)*1	High Gain	6500	6000	
	Low Gain	8200	9300	
Wavelength repeatability		+/- 0.2 nm, Continuous 100 measurements (Ar Light Source)		
Wavelength accuracy		± 1 nm (Testing environment is based on SW2560-050-NIRC's parameter, and accuracy may be up to ± 1.5nm according to different environment such as severe temperature change and long-time vibration. OtO can provide wavelength calibration software if customers needed.)		

*1:DynamicRange=65535/Average Dark Noise & (65535/up limit Dark Noise)

OtO Photonics

SW Series Product sheet

Specification		Value					
		SW2860	SW2870	SW2930	SW2960	SW2970	
Sensor		256Pixel	512Pixel	256Pixel	256Pixel	512Pixel	
		One stage cooling		Two stage cooling			
Spectrometer		SW series; Czerny-Turner Optical Layout, 2nd & 3rd order elimination					
Dimension		130(L) x 96(W) x 57.65(H) mm					
Parameters of Optical System		f/# : 5, NA :0.1, Focal Length(R1-R2) :60-60 (It is recommended that the Incident NA should larger than the NA of spectrometer.)					
Wavelength		900-1700 nm		910-2200nm	900-2500nm		
Slit (um)		50/100/150/200	25/50/100/150/200	50/100	50/100		
Integration time		High Gain		100 μs ~ 24s	100us-300ms	100us-20ms	
		Low Gain		100 μs ~ 24s	100us~3000ms	100us-200ms	
Dark Noise (average)		High Gain	8	9	11*1	8.5*1	11*1
		Low Gain	5	7	7*1	5.5*1	7*1
SNR (Single acquisition)		High Gain	3200 (0 ° C)	3200 (0 ° C)	3000*1	2200*1	3000*1
		Low Gain	4500 (0 ° C)	4500 (0 ° C)	5300*1	4300*1	6000*1
Dynamic range		High Gain	8000 (0 ° C)	7200 (0 ° C)	6000*1	7000*1	6000*1
		Low Gain	13000(0 ° C)	9300 (0 ° C)	9300*1	12000*1	9300*1
Wavelength repeatability		+/- 0.2 nm, Continuous 100 measurements (Ar Light Source)					
Wavelength accuracy		± 1 nm (Testing environment is based on SW2530-050-NIRA's parameter, and accuracy may be up to ± 1.5nm according to different environment such as severe temperature change and long-time vibration. OtO can provide wavelength calibration software if customers needed.)					

*1 : @100us, -20 ° C

OtO Photonics

SW Series Product sheet

Spec		Value						
		SW2520	SW2560	SW2570	SW2860	SW2870	SW2930	SW2960
Thermal Stability (nm/°C)		<0.2	<0.1			<0.2		<0.1
Environmental Conditions	Storage	-30°C to +70°C						
	Operation	0°C to +50°C						
	Humidity	0% - 90% non-condensing						
Interfaces		USB 2.0 @ 480 Mbps (High speed)						
Input fiber connector		SMA905: $\Phi 3.18 \pm 0.005 \text{mm}$						
Power		Power requirement (master): 300mA at +5 VDC Supply voltage: 4.75-5.25 Power-up time : < 4s Maximum USB input power Vcc : +5.25VDC Maximum I/O signal voltage : +5.5VDC		Power requirement (master): 350mA at +5 VDC DC Jack for TEC : 1300mA at 5VDC		Power requirement (master): 480mA at +5 VDC DC Jack for TEC : 2200mA at 5VDC		

- It's able to build Shutter in all SW series spectrometers. E.g: The Model name will change from SW2560 (without shutter) to SW2560S(with shutter).
- Customized design for your various special requirements including higher resolution, specific wavelength range, higher SNR, special gratings or sensors not in the list, specific software or hardware design, or special exposure modes, is welcome and will be elaborately built and tested by our R&D team.

OtO Photonics

SW Series Product sheet

■ Structure

▶ 3.1 Mechanical Diagram

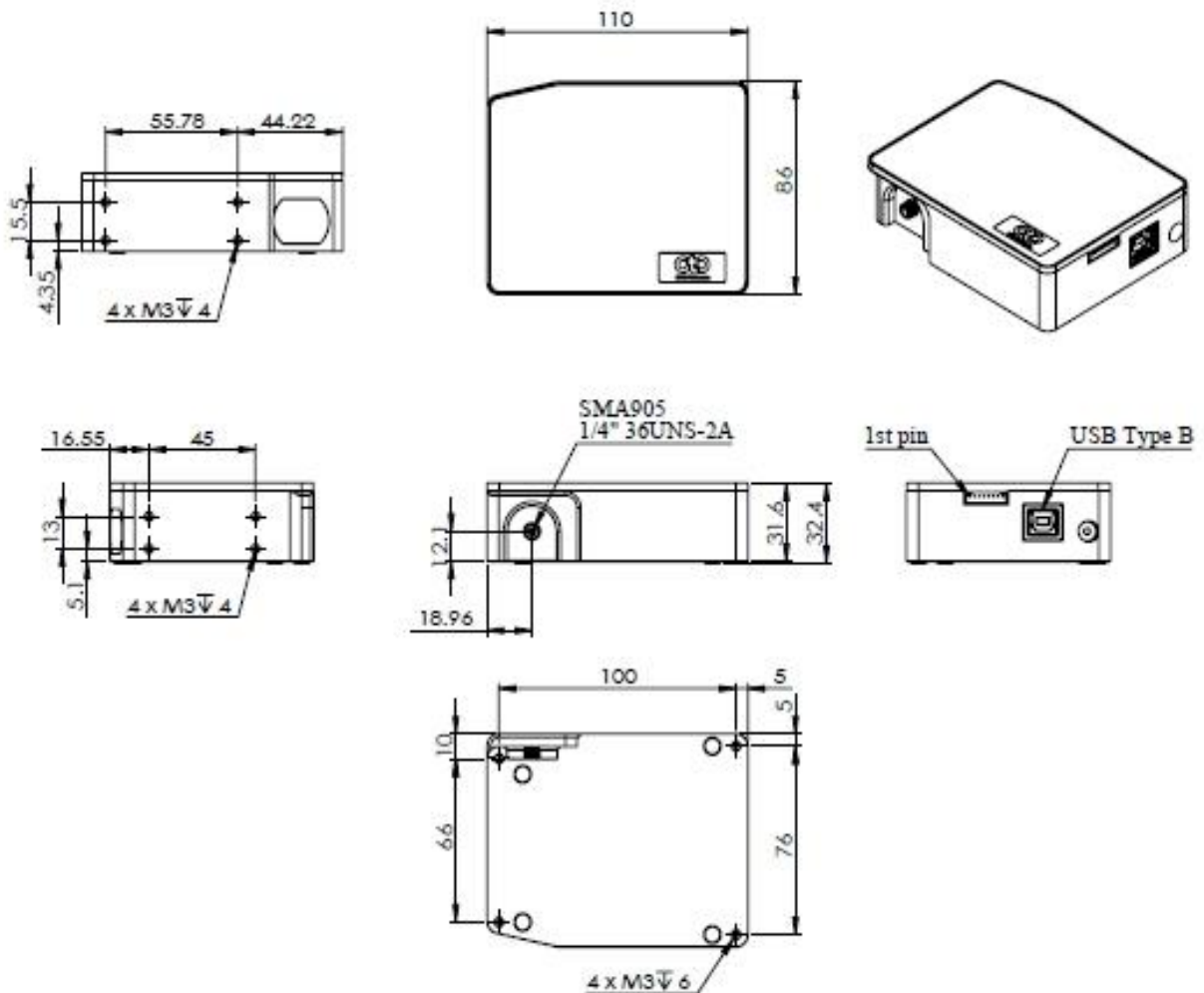

Fig. 1: SW 5 Series outer dimensions(TYPE I)

OtO Photonics

SW Series Product sheet

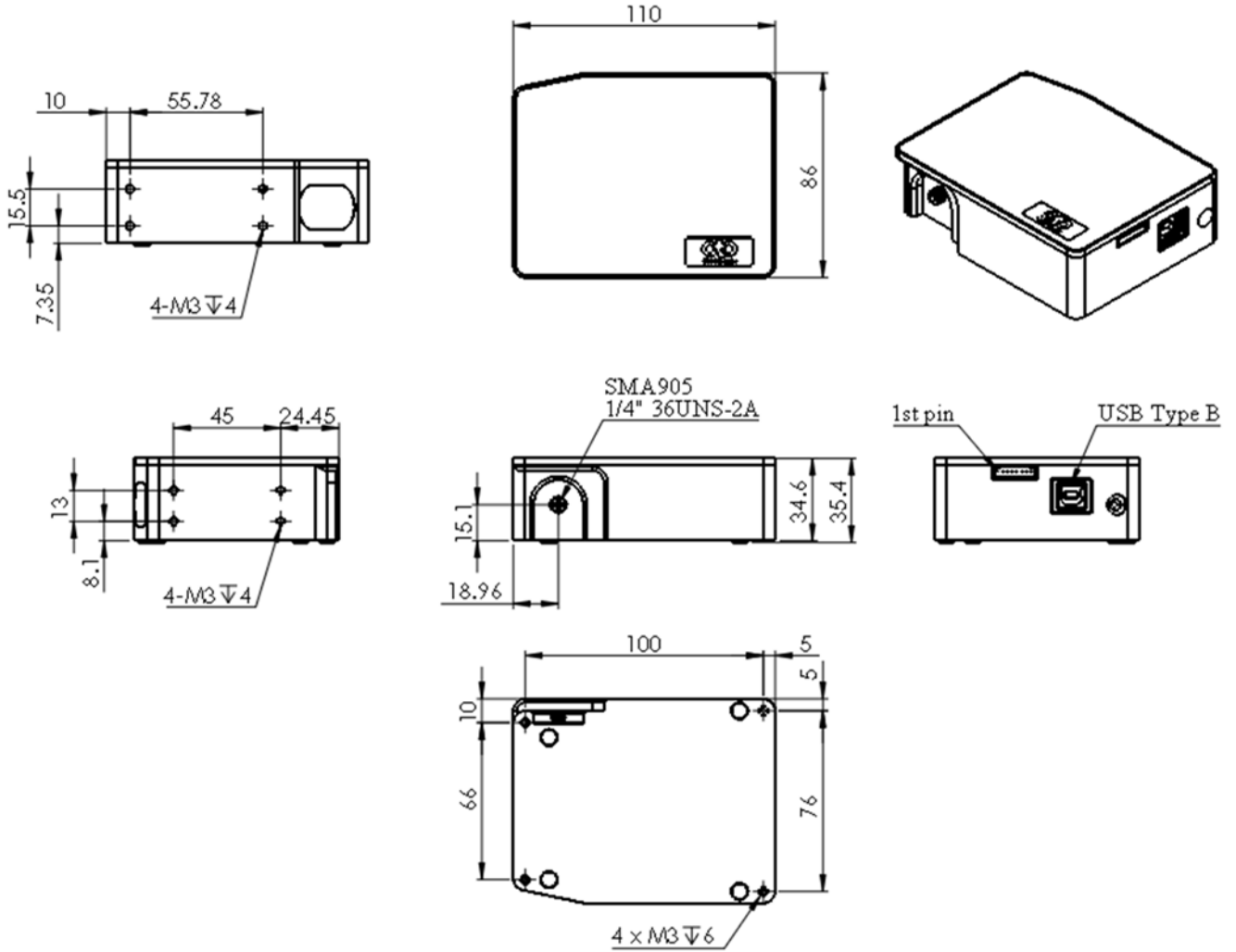

Fig. 2: SW 5 Series outer dimensions(TYPE II)

OtO Photonics

SW Series Product sheet

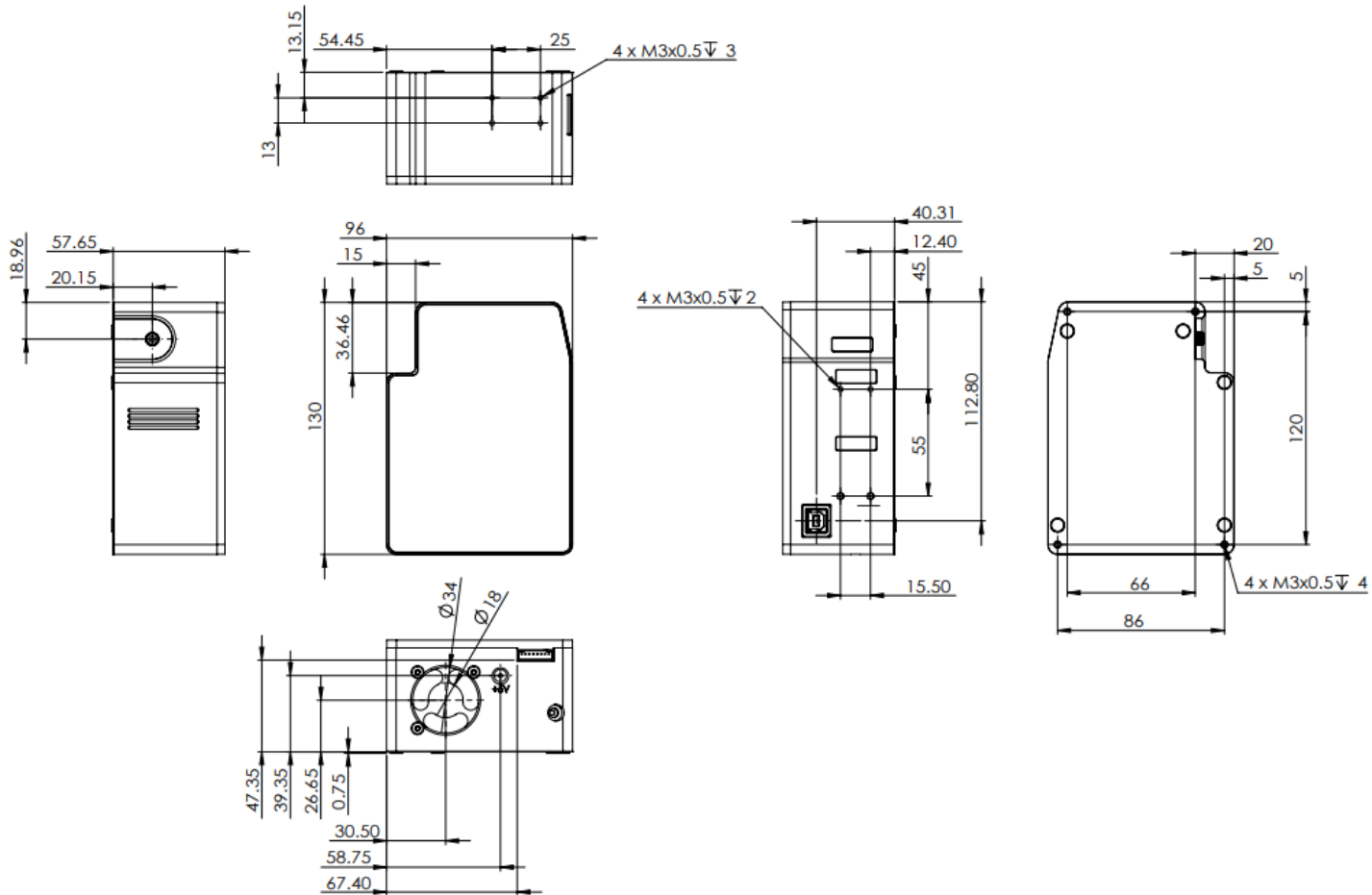
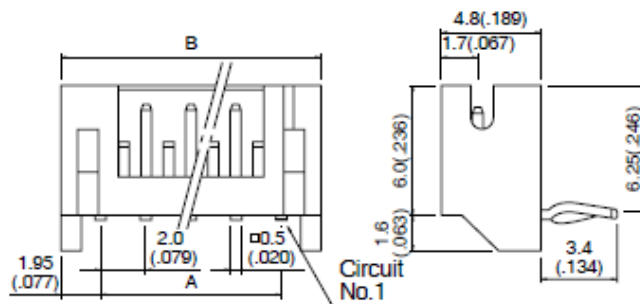

Fig. 3: SW 8 & 9 Series outer dimensions

► 3.2 Electrical Pinout

The following list is the pin description for the SW Series Extension Connectors.
The Extension Port is a 8 pin 2.0mm connector.

Side entry type



Cir- cuits	Model No.		Dimensions mm(in.)		Q'ty / box	
	Top entry type	Side entry type	A	B	Top entry type	Side entry type
8	B 8B-PH-K-S	S 8B-PH-K-S	14.0(.551)	17.9(.705)	500	250

Fig. 4 : Extension Port 2.0 mm 8 pin drawing

OtO Photonics

SW Series Product sheet

Extension Port Pin# Description Alt Function

*All I/Os are TTL-level input/output

Pin No.	Direction	Pin Name	Function Description
1	Power	5V Output	When connecting to PC USB port, this pin is also connected to VBUS. This pin can provide around 0.1A power for external device.
2	Output	TX	UART TX. TX is the output from the RISC controller.
3	Input	RX	UART RX. RX is the input for the RISC controller.
4	Output	GPIO0	General Purpose Output 0.
5	Output	GPIO1	General Purpose Output 1.
6	Output	LS_ON	Light Source Turn ON.
7	Input	Trigger_IN	External Trigger Input Signal.
8	GND	GND	GND

● Pin orientation

Looking at Front of SW Series connector side, from left to right are Back Extension Port and PC USB.

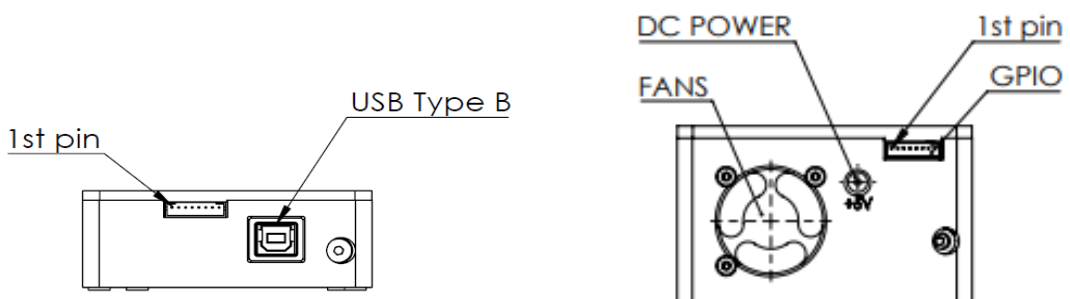

Fig. 5 : SW Series the front-view of connector mechanical graph

OtO Photonics

SW Series Product sheet

► 3.3 Detector Overview

● InGaAs DETECTOR

InGaAs sensor is high sensitive in NIR region. The linear array type is suitable for quick and accurate spectrum measurement. A built-in timing generator and clock-drivers ensure single 5V power supply for use.

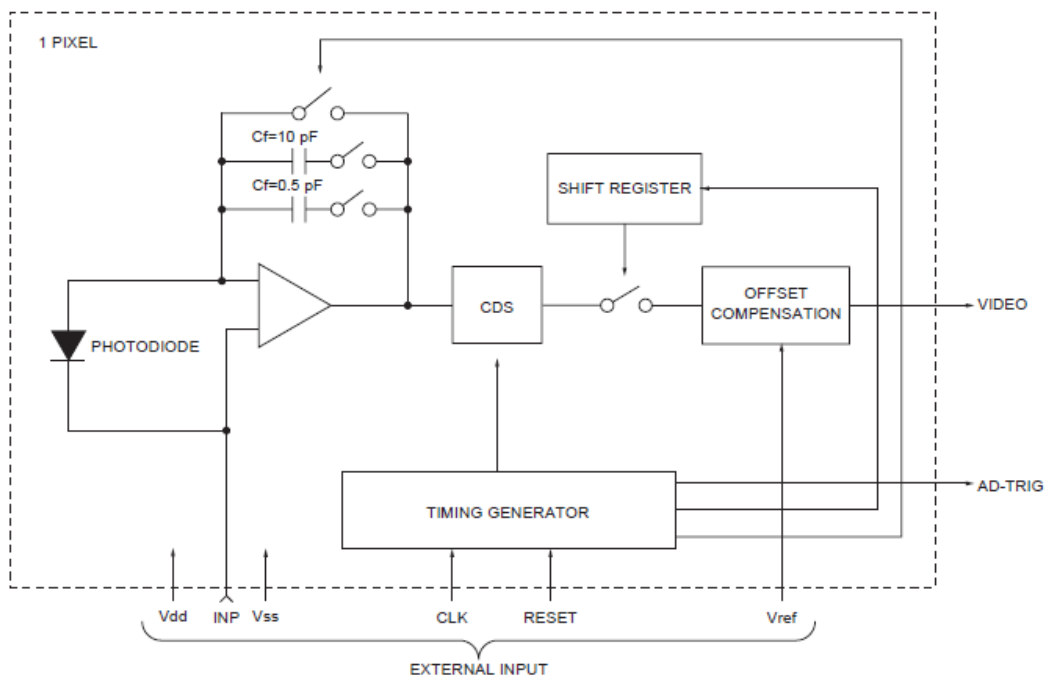

Fig. 6: InGaAs Sensor Block Diagram (for reference, depended on different Sensor)

OtO Photonics

SW Series Product sheet

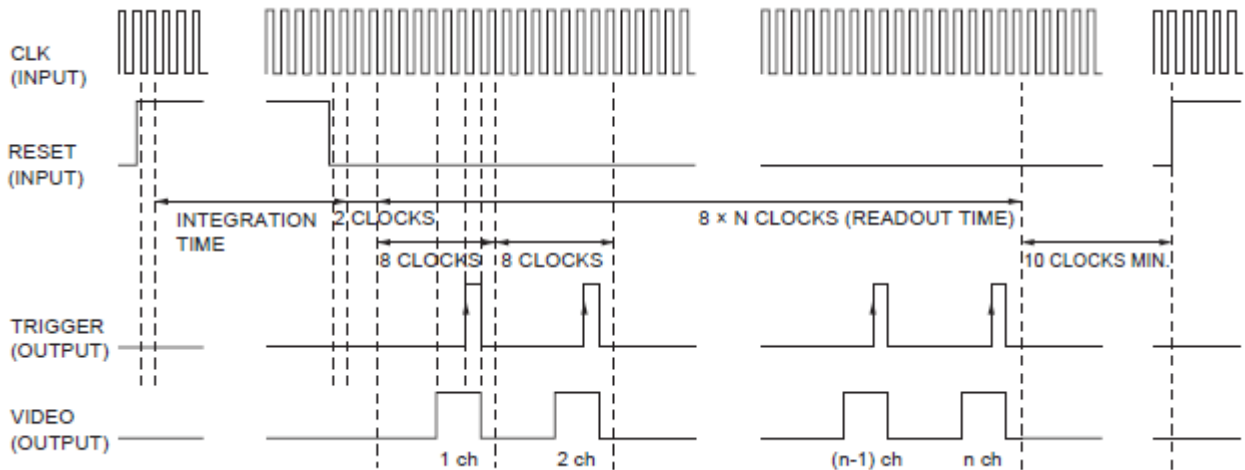

Fig.7: InGaAs sensor operation timing waveform
(for reference, depended on different Sensor)

The output signal is proportion to the integration time. When the light power or integration time is long enough to fully charge the pixel, the sensor output will be saturated. Per the characteristic of the sensor, the over-saturated condition may cause the abnormal response.

- **Sesnor/SYSTEM NOISE**

There are three major sources impact the Vout signal reading. One is the light source stability, the second is the electronics noise, and the other is detector noise. If we don't consider the outer light source influence, we can check the dark noise performance of this system first. The dark noise we define here is the RMS of Vout signal under 10ms (SW25, SW28 series), or 0.1ms (SW29 series) integration time in dark condition. So the dark noise will be only contributed by electronics readout noise and the sensor.

The other major parameter to define the noise performance is the SNR. The SNR we define here is the ratio of the full signal (65535 counts) to the RMS value under the full signal condition. The higher SNR performance indicates the readout signal is more stable. It will be helpful for the low signal differentiation.

- **SIGNAL AVERAGING**

The software-SpectraSmart provides two options for the signal curve operations. The first one is the signal averaging. By the averaging method, we can reduce the noise impact on each pixel. Surely, more sampling points will bring the better averaging performance. But it will need more time to get one spectra. When we use the time-base type of signal averaging, the S:N increases by the square root of the number of samples. Thus, a S:N is readily 10x achieved by averaging 100 spectra.

The other curve smoothing is boxcar filter. It can average the adjacent points to show the smoother curve, but it will lower optical resolution. So if the target signal is peak type, the boxcar may not be suitable for this.

These two methods can be enabled at the same time if the measurement target is suitable for this operation. But if the user would like to check all the original data and performance, time-based average or boxcar smoothing needs to be un-checked. The default setting for these two average methods is un-checked.

■ Internal Operation

▶ 4.1 Pixel Definition

The baseline signal is around 1,000 counts in our current system. We can provide the tool/command to manually adjust the baseline. (adjust the AFE OFFSET) The other baseline adjustment method is to enable the background removal from the software. It depends on the user how to use the baseline.

▶ 4.2 Digital Inputs & Outputs

● General Purpose Inputs/Outputs (GPIO)

SW Series has 6 user programmable 3.3V digital Input/Output pins, which can be accessed at the 8-pin Extension connector. Through software, the state of these I/O pins can be defined and used for multi-purpose applications. If the user needs the special timing generation (like single pulse or PWM), SW Series provides the flexibility to implement this.

OtO Photonics

SW Series Product sheet

GPIO Recommended Operating Levels:

VIL(max) = 0.8V

VIH(min) = 2.0V

GPIO Absolute Maximum/Minimum Ratings are as follows:

VIN(min) = -0.3V

VIN(max) = 5.5V

● Communication and Interface

USB 2.0

480-Mbit **U**niversal **S**erial **B**us is the standard and popular communication interface in PC. Our PC software allows connecting multiple SW Series via USB and monitors multiple SW Series spectra. The low power requirement allows operating the SE Series through the USB cable and VBUS.

● Extremely Precise Continuous Multiple Exposures

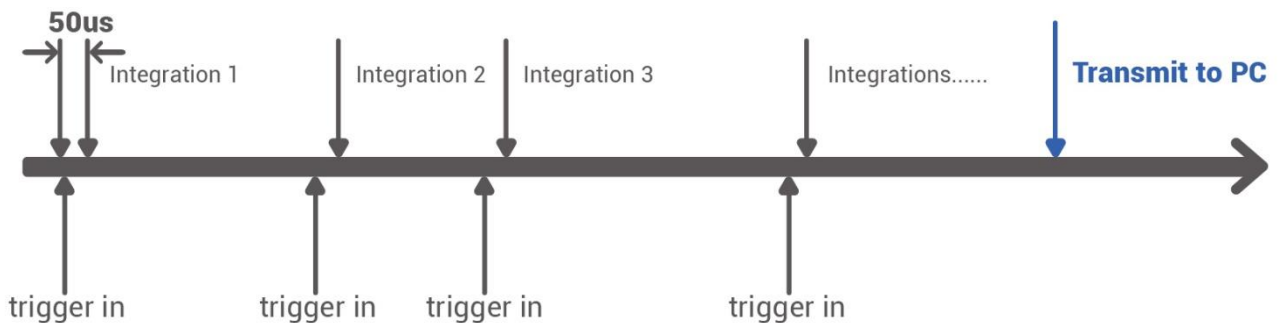

- ❑ Arbitrary integration times
- ❑ Spectra are stored in the huge memory on our board, providing up to 4000 spectra buffering
- ❑ After all integrations are done, the spectra are transmitted to your PC

■ **USB Port Interface Communications and Control Information**

▶ **Overview**

SW Series is a microcontroller-based Miniature Fiber Optic Spectrometer that can communicate via the Universal Serial Bus. This section contains the necessary programming information for controlling SW Series via the USB interface. This information is only pertinent to users who wish to not utilize SpectraSmart software to interface to SW Series.

● **Hardware Description**

SW Series utilizes a 32 bit RISC controller built in USB 2.0. Program code and data coefficients are stored in SPI Flash. The RISC controller supports 64 MByte DDR and 64 Mbits Flash.

SW Series Product sheet

- **USB Info**

SW Series USB Vendor ID number is 0x0638 and the Product ID is 0x0AAC. SW Series is USB 2.0 compliance. The data exchange between host and spectrometer is via bulk streams. The detail USB information please refer USBIF @ <http://www.usb.org>.

- **INSTRUCTION SET**

Application Programming Interface

The list of the APIs is shown in the following table followed by a detailed description of each function call.

□ **Open SW Series Spectrometer**

Description: To connect Windows host to SW Series

a.Function Name: UAI_SpectrometerOpen

b.Arguments:

dev: 8 SW Series spectrometers can be attached to one host at the same time. dev is the device number to specify which one will be opened.

handle: the unique Windows identifier to operate devices. Windows will return the identification number which is necessary for further operation.

SW Series Product sheet

❑ Query Frame Size

Description: To get the data frame size of the spectrometer.

a.Function Name: UAI_SpectromoduleGetFrameSize

b.Arguments:

device_handle: a pointer to the device information structure which is returned

when device open.

size: a 16-bit unsigned integer will be returned to indicate the data length.

❑ Acquire Wavelength

Description: Initiates a wavelength acquisition. SW Series will acquire a complete wavelength distribution.

a.Function Name: UAI_SpectrometerWavelengthAcquire

b.Arguments:

device_handle: a pointer to the device information structure which is returned when

device open.

buffer: the storage buffer acquired data.

SW Series Product sheet

□ Acquire Spectra

Description: Initiates a spectra acquisition. SW Series will acquire a complete intensity distribution which corresponds to the wavelength which is acquired by OtO_UAI_SpectrometerWavelengthAcquire.

a. **Function Name:** UAI_SpectrometerDataAcquire

b. **Arguments:**

device_handle: a pointer to the device information structure which is returned when device open.

integration_time_us: a 32-bit unsigned variable to determine the integration time of the micro-seconds.

buffer: the storage buffer acquired data.

average: the spectrum could be averaged by several continuous acquisitions to reduce the noise.

□ Query Wavelength Range

Description: To get the minimum and maximum wavelength

a. **Function Name:** UAI_SpectromoduleGetWavelengthStart

Function Name: UAI_SpectromoduleGetWavelengthEnd

b. **Arguments:**

device_handle: a pointer to the device information structure which is returned when device open.

lambda: a 32-bit floating type data which is indicate the minimum or maximum wavelength, in nm, of SW Series will be returned.

❑ Query Integration Time Range

Description: To get the minimum and maximum integration time.

a.Function Name: UAI_SpectromoduleGetMinimumIntegrationTime

Function Name: UAI_SpectromoduleGetMaximumIntegrationTime

b. Arguments:

device_handle: a pointer to the device information structure which is returned when

device open.

Integration Time: a 16-bit integer type data which indicates the minimum or maximum integration time of SW Series will be returned. The minimum integration

time is in micro-second and the maximum Integration time is in milli-second.

❑ Close SW Series Spectrometer

Description: To connect Windows host to SW Series

a.Function Name: UAI_SpectrometerClose

b.Arguments:

handle: the unique Windows identifier to operate devices. Windows will detach

the device and any operation is invalid after this function is executed.