

Introduction

SilverBullet (SB) series spectrometers introduce a concave mirror optical design for an extremely compact and light package.

Based on 8-bit 8051 microcontrollers SB series spectrometers provide short integration time, fast readout speed, high accuracy trigger timing and low power consumption. Alternatively, models configured with a traditional 32-bit RISC microcontroller are also available. These versions offer more buffer memory and can operate in multiple transmission mode.

The high speed 1024-pixel CMOS sensor enables excellent resolution.

The SB series is powered and connected to a computer via USB with an additional interface providing six I/O pins for connecting external devices.

SB series spectrometers can be operated using OtO Photonics' SpectraSmart spectral measurement software which includes an SDK.



This document is intended for sales and marketing purposes only and may not serve as a specification document for shipping or contracts. If a specification for product approval or IQC is required please contact OtO or your distributor.

OtO Photonics

Silver Bullet Series Product Sheet

Precautions

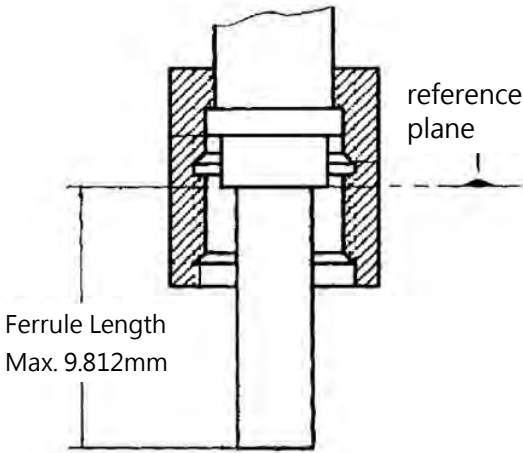
Picture	Description
	<p>Screw in the fiber optic connector with fingers. Do not use any tool to tighten it. Using tools such as wrenches to tighten the connector may cause the connector to press against and damage the inlet slit of the spectrometer. Such damage is not covered by the warranty.</p> <p>In cases where the connector needs to be firmly in place for long-term use, it is advised to apply a little glue to where the SMA905 connector is connected to the spectrometer.</p>
	<p>The SMA905 connectors on all spectrometers made by OtO Photonics are manufactured in accordance with international standards. Customers should ensure that the ferrule length of the fiber used is not longer than 9.812mm to avoid damaging the slit in the SMA950 connector. Such damage is not covered by the warranty.</p>

This document is intended for sales and marketing purposes only and may not serve as a specification document for shipping or contracts. If a specification for product approval or IQC is required please contact OtO or your distributor.

OtO Photonics

Silver Bullet Series Product Sheet

■	Overview	
1.1	SB Series Products	P4
1.2	Response Curves	P5
■	Key Features	
2.1	Characteristics	P6
2.2	Features	P7
■	Mechanical Designs	
3.1	Outlines and Dimensions	P8
3.2	Electronic Output Pin Assignments	P10
3.3	Sensor Overview	P12
■	Operations	
4.1	Pixel Signal Intensity	P13
4.2	Digital Input/Output	P13
4.3	Trigger Modes	P15
■	USB Data Transfer and Controls	P17

This document is intended for sales and marketing purposes only and may not serve as a specification document for shipping or contracts. If a specification for product approval or IQC is required please contact OtO or your distributor.

OtO Photonics

Silver Bullet Series Product Sheet

Overview

1.1 SB Series Products

Model	Wavelength range (nm)			SNR	Dynamic Range ^{*1}	A/D	Stray Light	Thermal Stability Test
	DUV2B	FUVA	VNIR7B					
	200 ~ 850	180 ~850	300-1100					
SB2134								
SB3134/ SB3130	√	√	√	350	5200	16 bits	0.3%	<0.04 nm/°c *2
SB4134/ SB4130								

*1 : 65535/Dark Noise(average)

*2 : Better thermal stability performance can be achieved. Please discuss this with the sales representative.

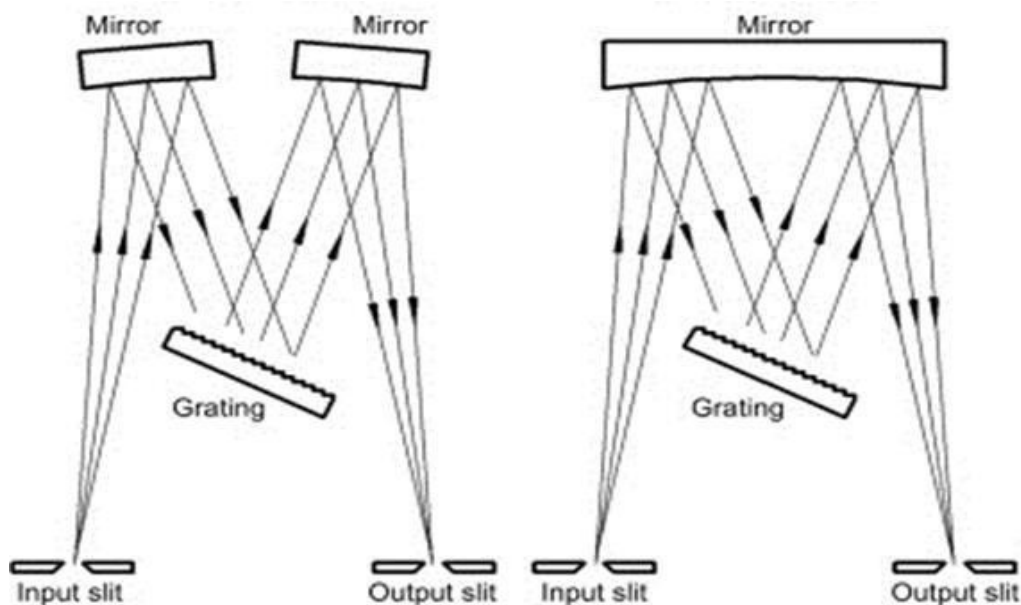

Fig. 1 : Concave Mirror Czerny-Turner Optical Design

This document is intended for sales and marketing purposes only and may not serve as a specification document for shipping or contracts. If a specification for product approval or IQC is required please contact OtO or your distributor.

OtO Photonics

Silver Bullet Series Product Sheet

► 1.2 Response Curves

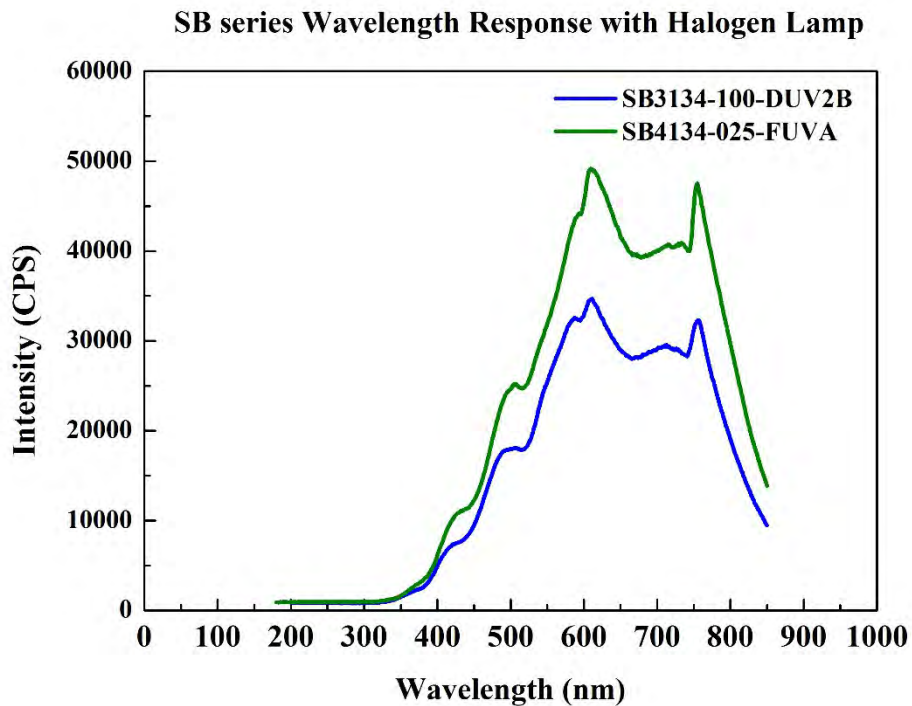
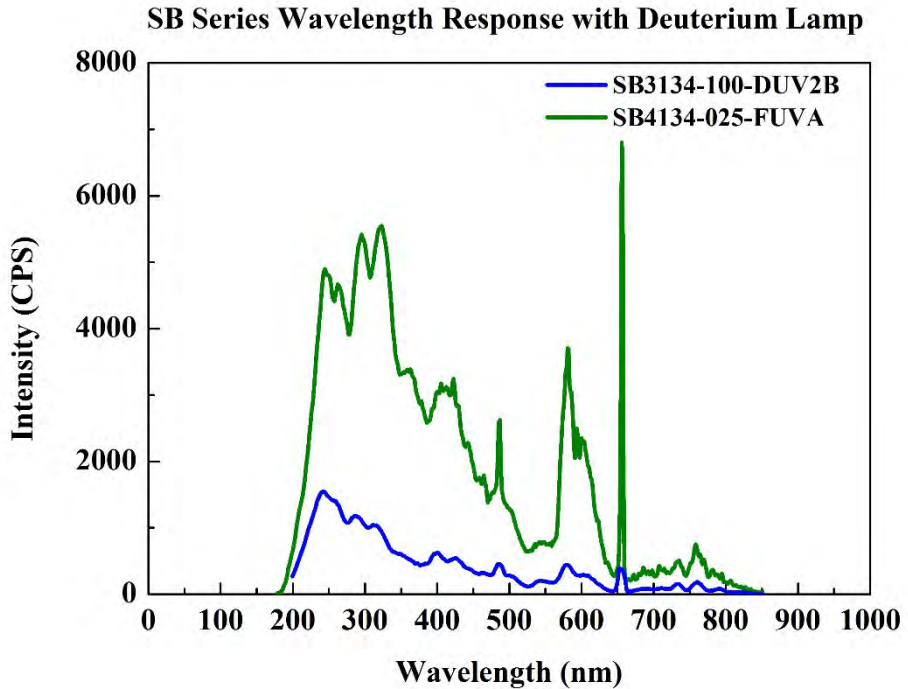

Fig. 2 : SB Series Deuterium Lamp & Halogen Lamp Response

OtO Photonics

Silver Bullet Series Product Sheet

■ Key Features

▶ 2.1 Characteristics

- Wavelength range: 180-850nm, 200-850nm, 300-1100nm
- Resolution 3 to 10.5nm, depending on the combination of various slits and gratings.
- Sensor:
 - ▣ High speed 1024pixel CMOS sensor
- Customizable modular components: grating and inlet slit
- Integration time: 6 μ s-65sec(Sensor Clock rate 10MHz)
21 μ s-65sec (Sensor Clock rate 5MHz)
- 16 bit, 15MHz A/D converter
- Micro USB, 4pin USB connector
- An 8-pin external I/O port (with a built-in LED indicator) for connecting external devices
 - ▣ 6 pins for digital I/O data acquisition
- Plug-n-Play computer application support
- Flash ROM storage
 - ▣ Wavelength calibration parameters
 - ▣ Linearity correction parameters
 - ▣ Intensity correction parameters

This document is intended for sales and marketing purposes only and may not serve as a specification document for shipping or contracts. If a specification for product approval or IQC is required please contact OtO or your distributor.

OtO Photonics

Silver Bullet Series Product Sheet

► 2.2 Specifications

Features		Specifications	
		SB2134/SB3134 / SB4134	SB2130/SB3130/SB4130
Sensor		1024 pixel CMOS	
Dark noise (average)		12.5	
Dynamic range		5200	
SNR		350	
Wavelength range		180~850nm (FUVA) 200~850nm (DUV2B) 300~1100nm (VNIR7B)	
Optical system characteristics		f/# : 4.5, NA : 0.11	
Optical design		Czerny-Turner Optical design, 2nd & 3rd harmonics removed	
Dimensions		40 (L) x 36.3 (W) x 25.1 (H) mm	49 (L) x 48 (W) x 28.5 (H) mm
Slit width		25 / 50 /100 μ m	
Resolution (FWHM)		3~15nm, depending on the combination of various slits and gratings.	
Integration time		6 μ s ~ 65sec (Sensor Clock rate 10MHz) 21us ~ 65sec (Sensor Clock rate 5MHz)	
Fiber optic interface		SMA905	
Environmental requirements	Storage temperature	-30°C to +70°C	
	Operating temperature	0°C to +50°C	
	Relative Humidity	0% - 90% non-condensing	
Data transfer interface		Micro USB	
Power specifications		Power supply: USB, 500mA at +5VDC Voltage: 4.75-5.25V	

OtO Photonics

Silver Bullet Series Product Sheet

■ Mechanical Designs

▶ 3.1 Outlines and Dimensions

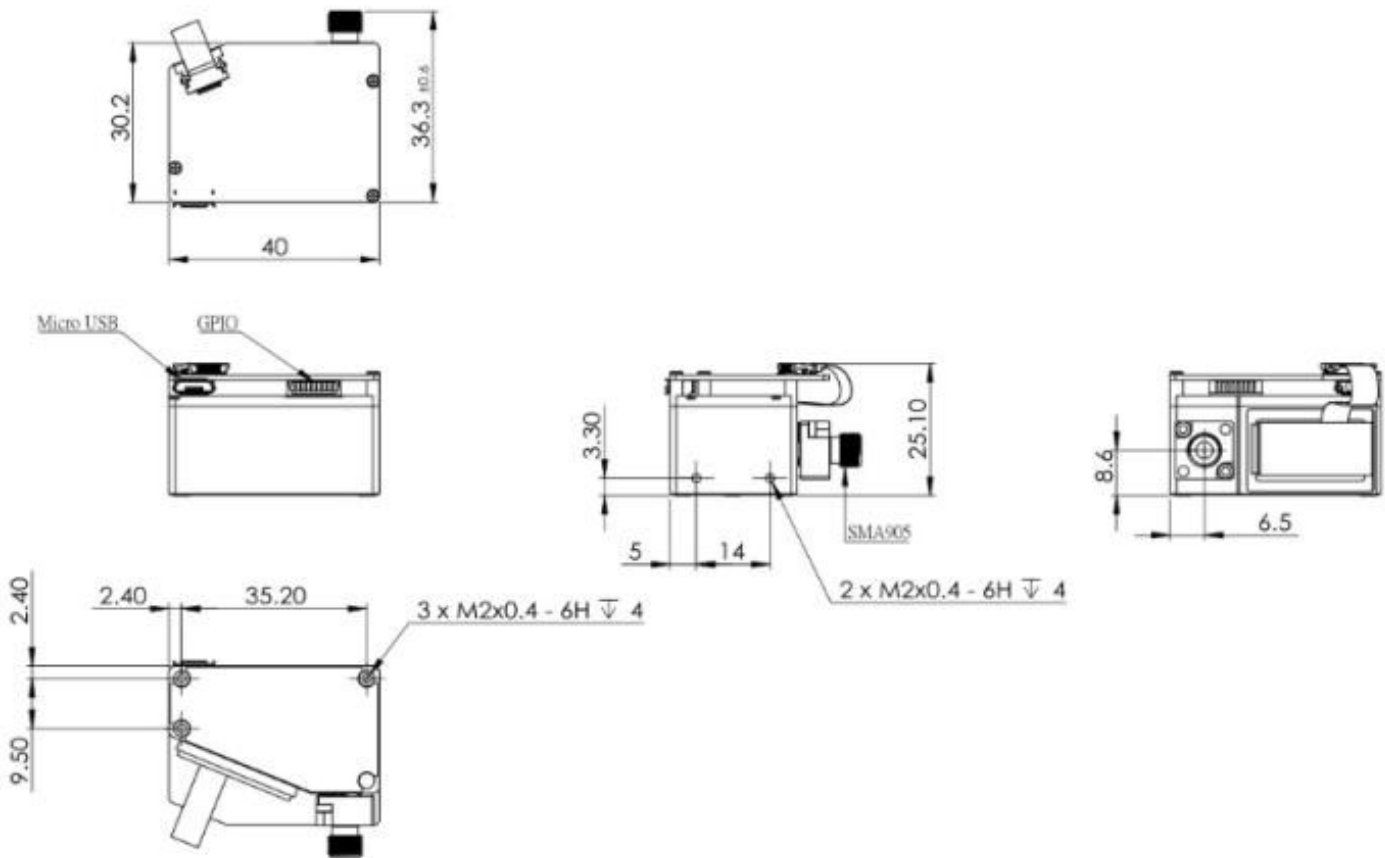

Fig. 3 : SB3134/4134 outlines and dimensions

This document is intended for sales and marketing purposes only and may not serve as a specification document for shipping or contracts. If a specification for product approval or IQC is required please contact OtO or your distributor.

OtO Photonics

Silver Bullet Series Product Sheet

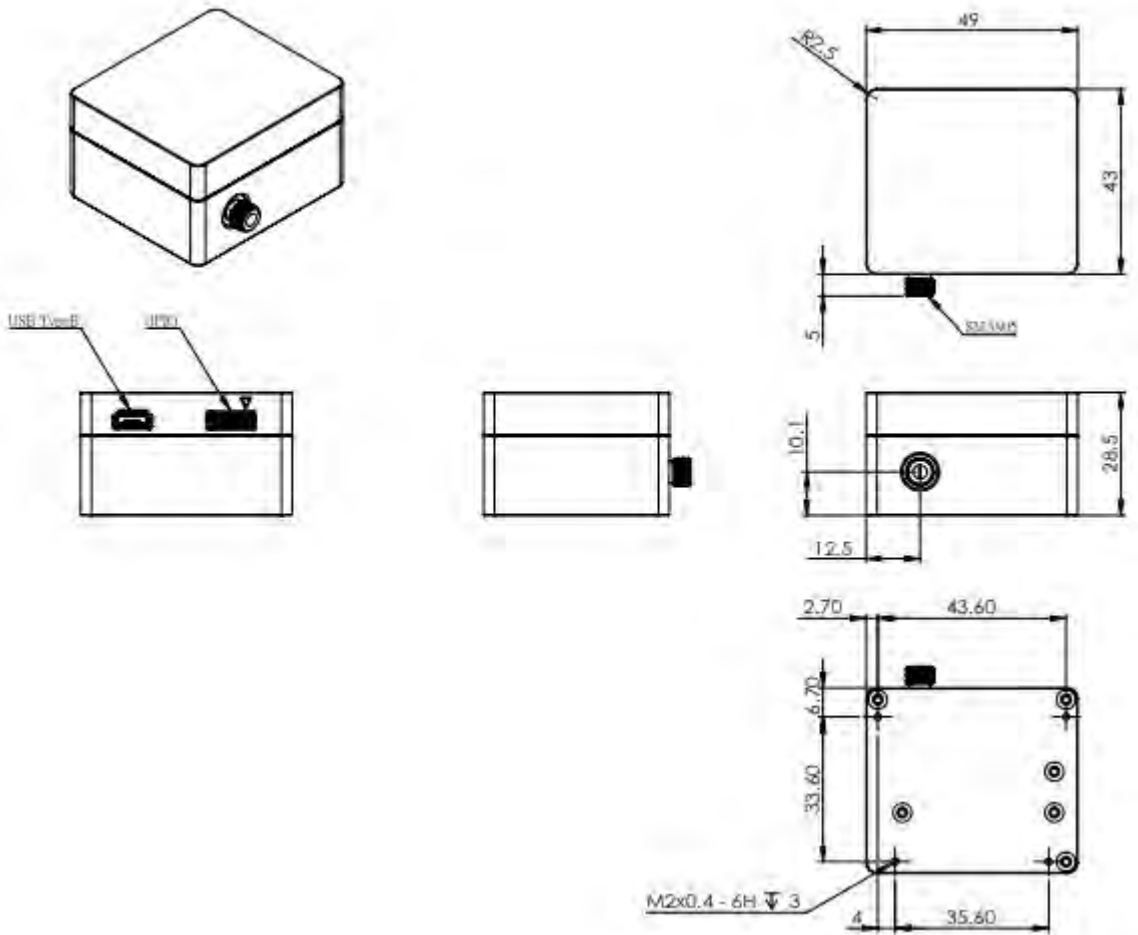

Fig. 4 : SB3130/4130 outlines and dimensions

This document is intended for sales and marketing purposes only and may not serve as a specification document for shipping or contracts. If a specification for product approval or IQC is required please contact OtO or your distributor.

OtO Photonics

Silver Bullet Series Product Sheet

► 3.2 Electronic Output Pin Assignments

The SB Series provides an 8-pin 1.0mm rear external I/O port.

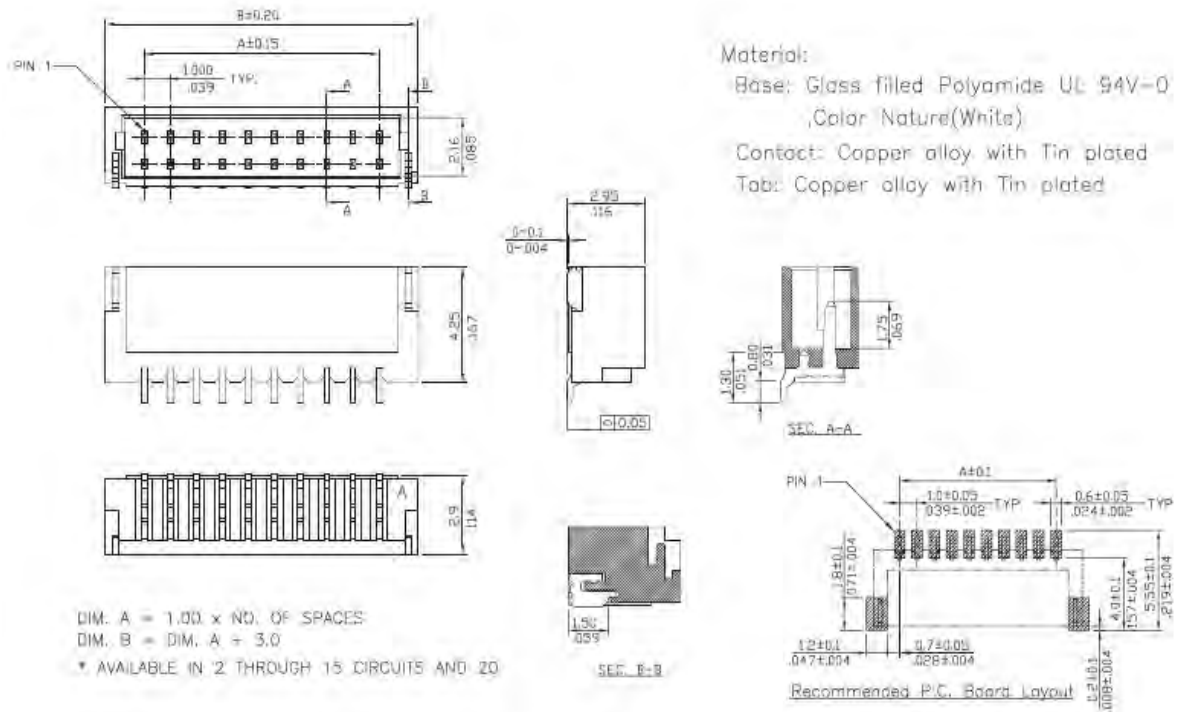

Figure 4. The 8-pin 1.0 mm rear external I/O port

This document is intended for sales and marketing purposes only and may not serve as a specification document for shipping or contracts. If a specification for product approval or IQC is required please contact OtO or your distributor.

OtO Photonics

Silver Bullet Series Product Sheet

● External Ports

The following figure shows the external ports on the SB Series. From left to right: the rear external I/O port, the PC USB port, and the LED indicator.

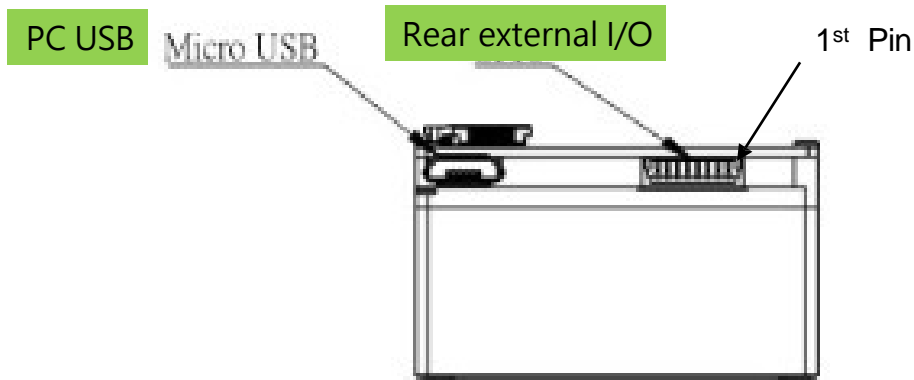

Figure 5. External ports on the SB Series

● Pin Assignments on the External I/O Port

Pin #	Type	Name	Description
1	Power	5V Input/Output	When the spectrometer is connected via USB to a computer, this pin connects to the VBUS so that the spectrometer can provide 0.1A of power to the external device.
2	Output	TX	UART TX. TX is the output from the 8051 microcontroller.
3	Input	RX	UART RX. RX is the input to the 8051 microcontroller.
4	Output	GPIO0	General purpose output #0.
5	Output	GPIO1	General purpose output #1.
6	Output	LS_ON	Lamp on.
7	Input	Trigger_IN	External trigger signal.
8	GND	GND	Ground.

OtO Photonics

Silver Bullet Series Product Sheet

► 3.3 Sensor Overview

● Sensor / System Noise

The three key factors that affect the noise level of the output signal are: stability of the light source, electronic noise, and the sensor noise. Excluding the effect of the external light source, the first thing to check is the dark noise of the measurement system. Dark noise is defined as the voltage output (V_{out} RMS) over a period of 10ms integration time in a completely dark environment. So the dark noise level is solely determined by the electronic noise in the readout and the CCD/CMOS sensor itself.

Another way to determine the quality of the signal is signal-to-noise ratio (SNR). SNR is defined as the maximum signal level (65535) divided by RMS. Higher SNR means the signal is cleaner, and differences between signals are more discernible when signal levels are low.

● Signal Averaging

In general, there are two ways to obtain a smooth curve for a signal: signal averaging and boxcar filter. Signal averaging can reduce the influence of noise on individual pixels. It is natural that increasing the number of samples taken for averaging creates a better averaged curve, but then it takes more time get the final spectrum. On the time-based curve, the signal-to-noise ratio (SNR) increases in proportion to the square root of the number of samples taken. For example, if the number of samples taken is 100, the SNR is increased 10 times.

The second method, boxcar filter, uses neighboring pixels for averaging to get a smooth curve for the signal, but it negatively impacts the optical resolution. This method is not recommended if you need to find the peak values of the signal. These two methods can be combined together in a single measurement if required.

This document is intended for sales and marketing purposes only and may not serve as a specification document for shipping or contracts. If a specification for product approval or IQC is required please contact OtO or your distributor.

OtO Photonics

Silver Bullet Series Product Sheet

■ Operations

▶ 4.1 Pixel Signal Intensity

The spectrometer is shipped with a baseline signal intensity at 1,000 counts. In cases where the user needs to modify this baseline intensity, it can be done using control commands. There is a command for the user to adjust the AFE OFFSET. Another way to change the baseline signal intensity is to use the "background removal" feature in the software. Which one to use depends on the way the user wants to use the baseline signal intensity.

▶ 4.2 Digital Input/Output

General purpose input/output (GPIO)

The SB Series comes with six 3.3V digital input/output pins that can be used for data acquisition on the 8-pin external I/O port. Using software, these I/O pins can be defined for different application purposes. To support some OEM customization needs, the SB Series provides the flexibility to use a special clock generator (such as single pulse or PWM).

This document is intended for sales and marketing purposes only and may not serve as a specification document for shipping or contracts. If a specification for product approval or IQC is required please contact OtO or your distributor.

OtO Photonics

Silver Bullet Series Product Sheet

GPIO recommended voltages:

$V_{IL}(\max) = 0.8V$

$V_{IH}(\min) = 2.0V$

GPIO maximum/minimum voltages:

$V_{IN}(\min) = -0.3V$

$V_{IN}(\max) = 5.5V$

● **Data transfer interface**

USB 2.0

The 480Mbit/s USB (Universal Serial Bus) is a widely used data transfer standard for computers. The spectrometer control software provided by OtO Photonics uses USB to connect to multiple SB Series spectrometers. The energy-saving SB Series can be powered via a USB cable over its VBUS line.

This document is intended for sales and marketing purposes only and may not serve as a specification document for shipping or contracts. If a specification for product approval or IQC is required please contact OtO or your distributor.

OtO Photonics

Silver Bullet Series Product Sheet

► 4.3 Trigger Modes

● Single trigger/single capture

In the single trigger/single capture mode (with preconfigured integration time), the spectrometer waits for a trigger pulse and captures the spectrum once upon receiving the trigger pulse. It can be triggered on a rising edge or a falling edge. An integration time programming delay can also be configured.

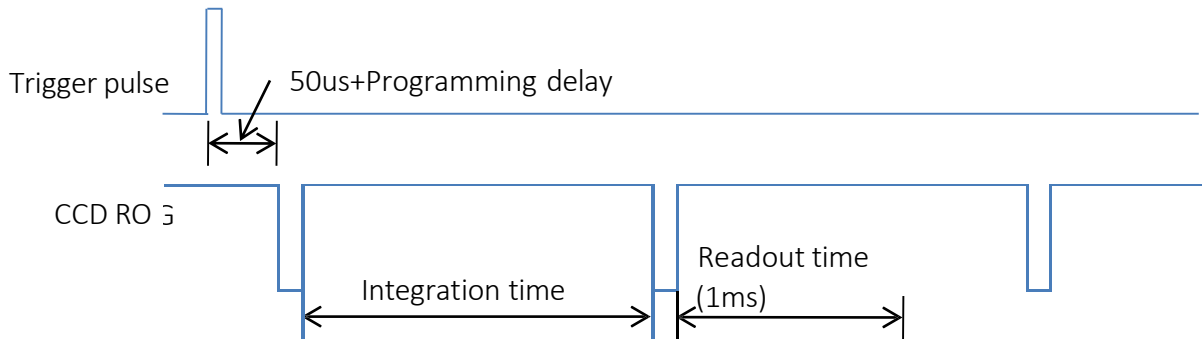

● Software trigger

In the software trigger mode (with preconfigured integration time), the spectrometer waits for the external trigger signal level to go up then starts and continues to capture the spectrum using preconfigured integration time till the signal level drops.



This document is intended for sales and marketing purposes only and may not serve as a specification document for shipping or contracts. If a specification for product approval or IQC is required please contact OtO or your distributor.

OtO Photonics

Silver Bullet Series Product Sheet

- **Software trigger/multiple capture**

In the software trigger/multiple capture mode (with preconfigured integration time and software commands to capture the spectrum), the spectrometer continues to capture the spectrum with the preconfigured integration time even when the trigger pulse drops.

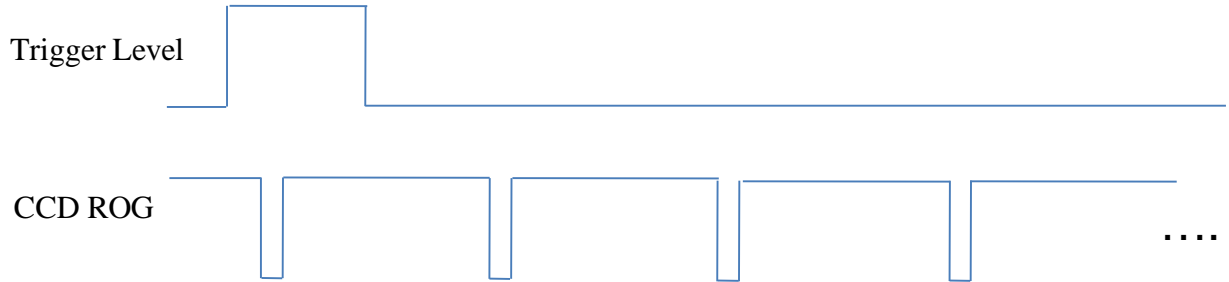

This document is intended for sales and marketing purposes only and may not serve as a specification document for shipping or contracts. If a specification for product approval or IQC is required please contact OtO or your distributor.

OtO Photonics

Silver Bullet Series Product Sheet

■ USB Data Transfer and Controls

▶ Overview

The SB Series is a compact spectrometer with an embedded microcontroller and supports USB data transfer. This section provides the computer programming details on how to control the SB Series via USB. This information is intended only for those who intend to develop their own software instead of using the standard software provided by OtO Photonics (SpectraSmart).

● Hardware Description

The SB Series leverages the built-in 8-bit 8051 microcontroller in the USB 2.0 chip. The program codes and data are stored in the I2C EEPROM.

● USB Information

SB Series USB Vendor ID: 0x0638; Product ID: 0x0AAC

The SB Series supports USB 2.0 connection and uses USB bulk streams for data transfer between the spectrometer and the computer. For more information on USB, please visit the USBIF website: <http://www.usb.org>

This document is intended for sales and marketing purposes only and may not serve as a specification document for shipping or contracts. If a specification for product approval or IQC is required please contact OtO or your distributor.

OtO Photonics

Silver Bullet Series Product Sheet

- **Programming Guide**

Application Programming Interface (API)

The following section provides a list of APIs and their functions.

❑ **Open SB Series Spectrometer**

Description: Connecting the computer to an SB Series spectrometer.

a. Function name: UAI_SpectrometerOpen

b. Parameters:

dev: Since one computer can connect up to eight SB Series spectrometers simultaneously, the 'dev' parameter specifies which device to connect to.

handle: A unique identifier returned by the API to identify the connected spectrometer. Each connected device is assigned a different handle. This handle is used by the API to identify which device to control in subsequent operations.

❑ **Get Frame Size**

Description: Getting the frame size of the sensor in the spectrometer.

a. Function name: UAI_SpectromoduleGetFrameSize

b. Parameters:

device_handle: The unique identifier for the spectrometer to be controlled.

size: Returning the frame size in 16-bit format.

❑ **Acquire Wavelengths**

Description: Starting to acquire wavelengths. The SB Series can acquire the complete distribution of wavelengths.

a. Function name: UAI_SpectrometerWavelengthAcquire

b. Parameters:

device_handle: The unique identifier for the spectrometer to be controlled.

buffer: The buffer to receive the data acquired.

This document is intended for sales and marketing purposes only and may not serve as a specification document for shipping or contracts. If a specification for product approval or IQC is required please contact OtO or your distributor.

□ Acquire Spectrum

Description: Starting to acquire the spectrum. The SB Series can acquire the complete spectrum corresponding to the data acquired by the "UAI_SpectrometerWavelengthAcquire" function.

a. Function name: UAI_SpectrometerDataAcquire

b. Parameters:

device_handle: The unique identifier for the spectrometer to be controlled.

integration_time_us: Specifying the integration time in 16-bit format (μ s).

buffer: The buffer to receive the data acquired.

average: The number of samples to take for signal averaging to reduce noise.

□ Get Wavelength Range

Description: Getting the supported maximum and minimum wavelengths.

a. Function name: UAI_SpectromoduleGetWavelengthStart

UAI_SpectromoduleGetWavelengthEnd

b. Parameters:

device_handle: The unique identifier for the spectrometer to be controlled.

lambda: Returning the maximum/minimum wavelength (nm) supported by the SB Series in 32-bit format.

□ Get Integration Time Range

Description: Getting the maximum/minimum integration time.

a. Function name: UAI_SpectromoduleGetMaximumIntegrationTime

UAI_SpectromoduleGetMinimumIntegrationTime

b. Parameters:

device_handle: The unique identifier for the spectrometer to be controlled.

Integration Time: Returning the maximum/minimum integration time supported by the SB Series in 16-bit format.

Note: The minimum integration time is specified in microseconds (μ s).
The maximum integration time is specified in thousand seconds (ks).

□ Close SB Series Spectrometer

Description: Disconnect the computer from the SB Series spectrometer.

a. Function name: UAI_SpectrometerClose

b. Parameters:

handle: The unique identifier for the spectrometer to be disconnected. The disconnected spectrometer will stop all of its operations when this command is executed.