

FEATURES

- Circular Active Area
- Ideal for 190-400 nm Detection
- 100% Internal QE
- UV Quartz Window Epoxy Bonded in Place

Electro-Optical Characteristics at 25 °C

Parameters	Test Conditions	Min	Typ	Max	Units
Active Area	Φ 5.5 mm		24		mm ²
Responsivity	(see graph on next page)	0.105	0.115		A/W
Shunt Resistance	V = ± 10 mV	50	100		MΩ
Reverse Breakdown Voltage, V _R	I _R = 1 μA	10	50		Volts
Capacitance, C	V _R = 0 V		1.2	1.5	nF
Rise Time	V _R = 0 V			1	us

Thermal Parameters

Storage and Operating Temperature Range	Units
Storage Temperature Range	-20° to 80°C
Operating Temperature Range	-20° to 80°C
Lead Soldering Temperature ¹	260°C

¹ 0.0625" from case for 10 seconds.

Typical Photon Responsivity

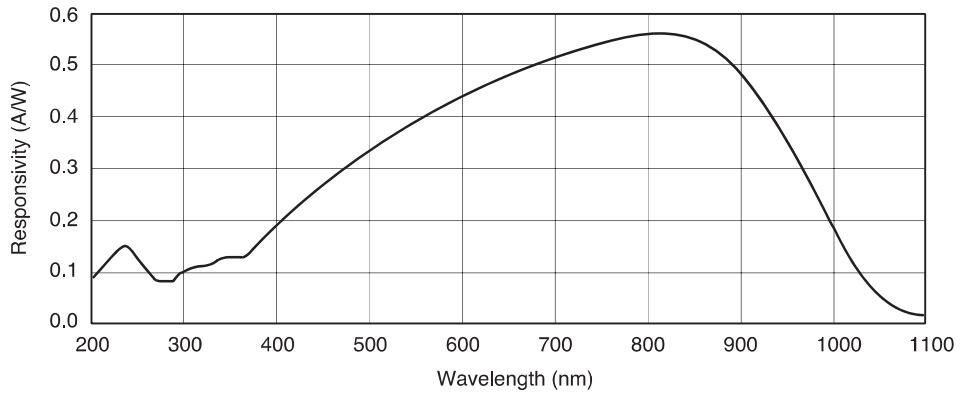

Capacitance vs. Voltage

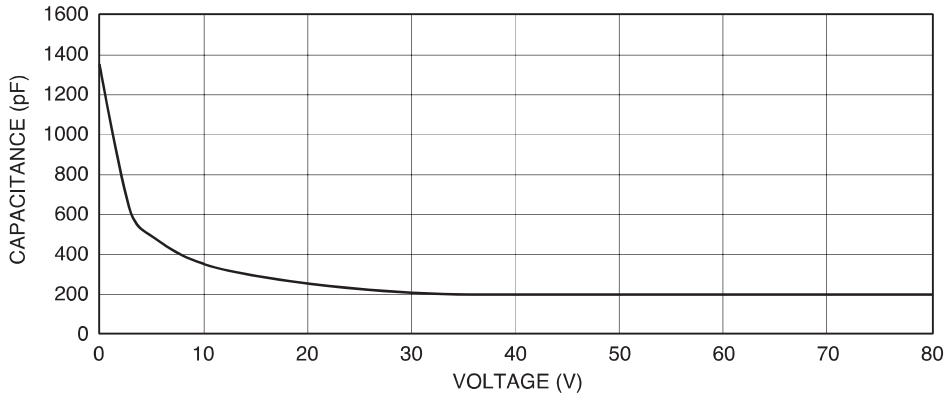

Dark Current vs. Voltage

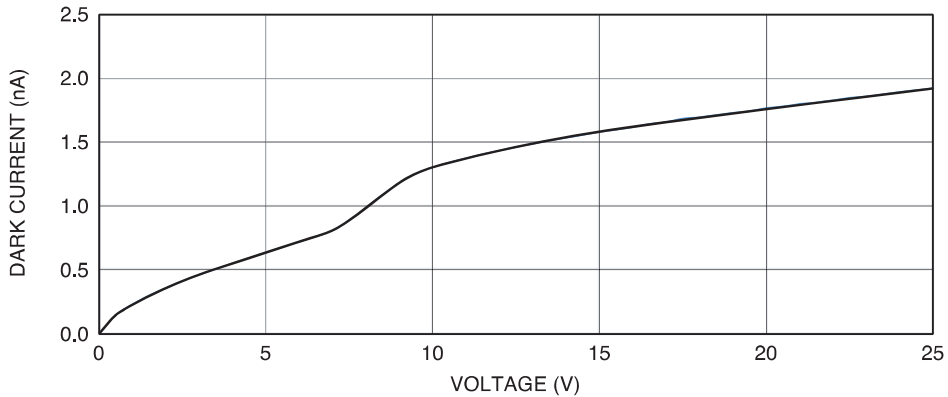

Package Information

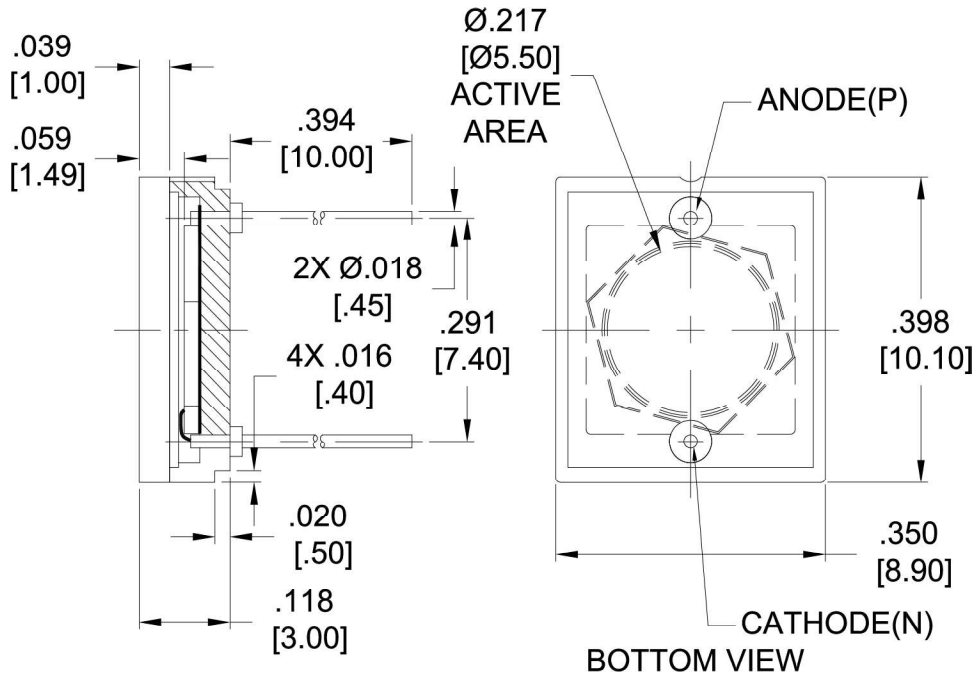

Dimensions are in inch [metric] units.

Specifications are subject to change without prior notice.