

FEATURES

- Circular Active Area
- Ideal for 193-400 nm Detection
- 100 % Internal QE
- No Cap for Maximum Responsivity
- Sacrificial Cap Taped on for Shipping Purposes

Electro-Optical Characteristics at 25 °C

Parameters	Test Conditions	Min	Typ	Max	Units
Active Area	Φ 4.1 mm		13.2		mm ²
Responsivity	(see graph on next page)	0.105	0.115	0.125	A/W
Shunt Resistance	V = ±10 mV	100	1000		Mohms
Reverse Breakdown Voltage, V _R	I _R = 1 μA	10			Volts
Capacitance, C	V _R = 0 V		3	7	nF
Response Time	V _R = 0 V			4	μsec

Thermal Parameters

Storage and Operating Temperature Range	Units
Storage Temperature Range	-20°C to 80°C
Operating Temperature Range	-20°C to 80°C
Lead Soldering Temperature ¹	240°C

¹ 0.0625" from case for 10 seconds.

Shipped with temporary cover to protect the photodiode and wire bonds.
 Review the Application Note, "Handling Precautions for AXUV, SXUV, and UVG Detectors", prior to removing cover.

Typical Photon Responsivity

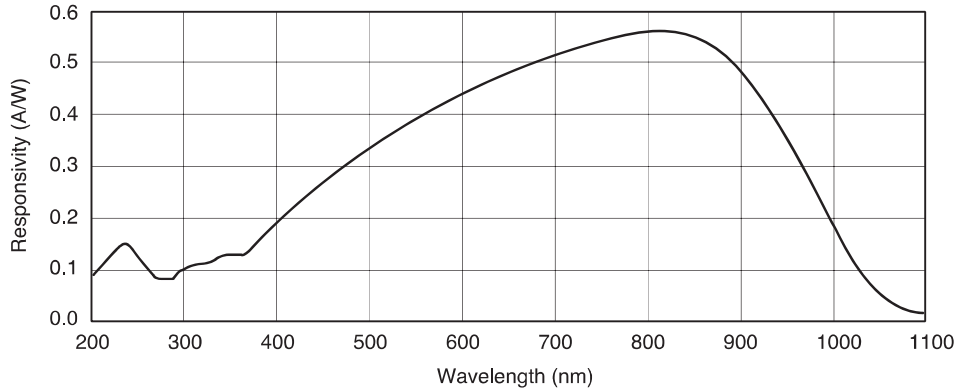

Package Information

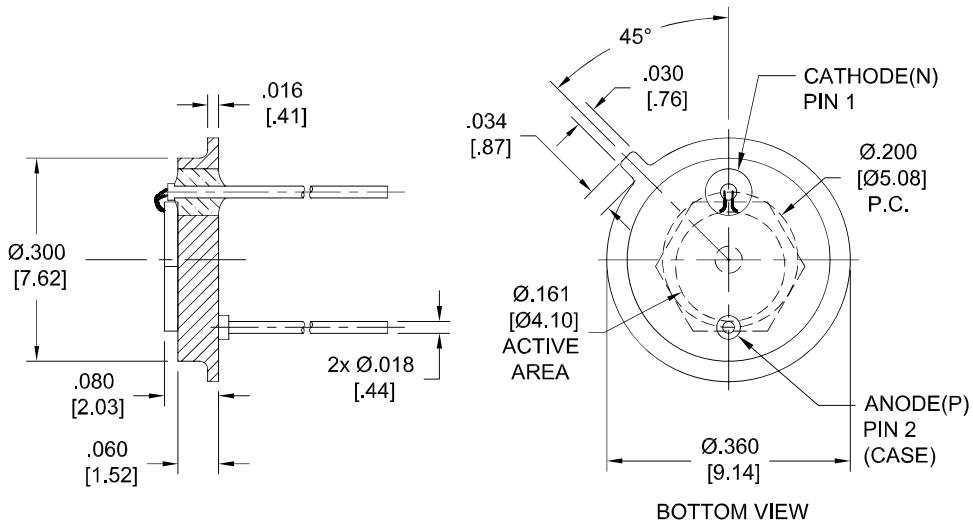

Dimensions are in inch [metric] units.

Specifications are subject to change without prior notice.