

FEATURES

- Red Enhanced
- Low Noise
- High Response
- High Shunt Resistance
- Low Profile TO-5 Package

Electro-Optical Characteristics at 25°C

Characteristic	Test Conditions	Min	Typ	Max	Units
Dark Current, I_D	$V_R = 5\text{ V}$		0.9	5	na
Shunt Resistance, R_{SH}	$V_R = 10\text{ mV}$		300		MΩ
Junction Capacitance, C_J	$V_R = 0\text{ V}, f = 1\text{ MHz}$		30		pF
Junction Capacitance, C_J	$V_R = 10\text{ V}, f = 1\text{ MHz}$		7.5		pF
Spectral Application Range, λ_{range}	Spot Scan	250		1100	nm
Responsivity, R	$\lambda = 633\text{ nm}, V_R = 0\text{ V}$	0.32	0.36		A/W
Responsivity, R	$\lambda = 900\text{ nm}, V_R = 0\text{ V}$	0.5	0.6		A/W
Breakdown Voltage, V_R	$I_R = 10\text{ }\mu\text{A}$	25	60		V
Noise Equivalent Power, NEP	$V_R = 0\text{ V}, \lambda = 950\text{ nm}$		2.5×10^{-14}		W/ $\sqrt{\text{HZ}}$
Response Time, t_r^1	$R_L = 50\text{ }\Omega, V_R = 0\text{ V}$		190		nsec
Response Time, t_r^1	$R_L = 50\text{ }\Omega, V_R = 10\text{ V}$		8		nsec

¹ Response time of 10% to 90% is specified at 660 nm.

Absolute Maximum Ratings at 25°C

Parameter	Min	Max	Units
Reverse Voltage, V_R		100	V
Storage Temperature, T_{STG}	-55	+150	°C
Operating Temperature, T_O	-40	+125	°C
Lead Soldering Temperature (1/16" from case for 3 sec)		+260	°C

Capacitance vs. Bias Voltage

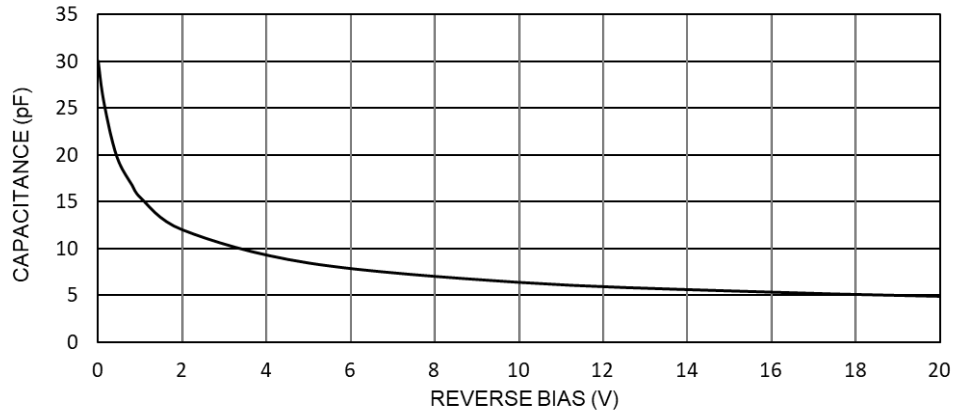

Typical Spectral Response

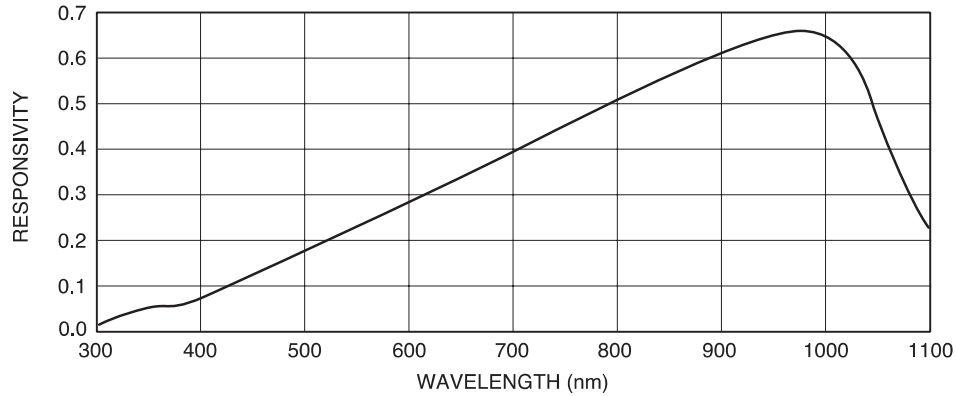

Dark Current vs Voltage

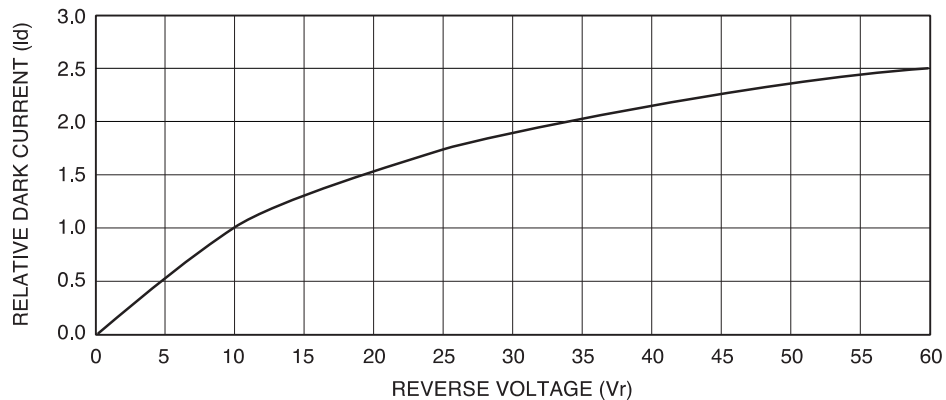

Package Information

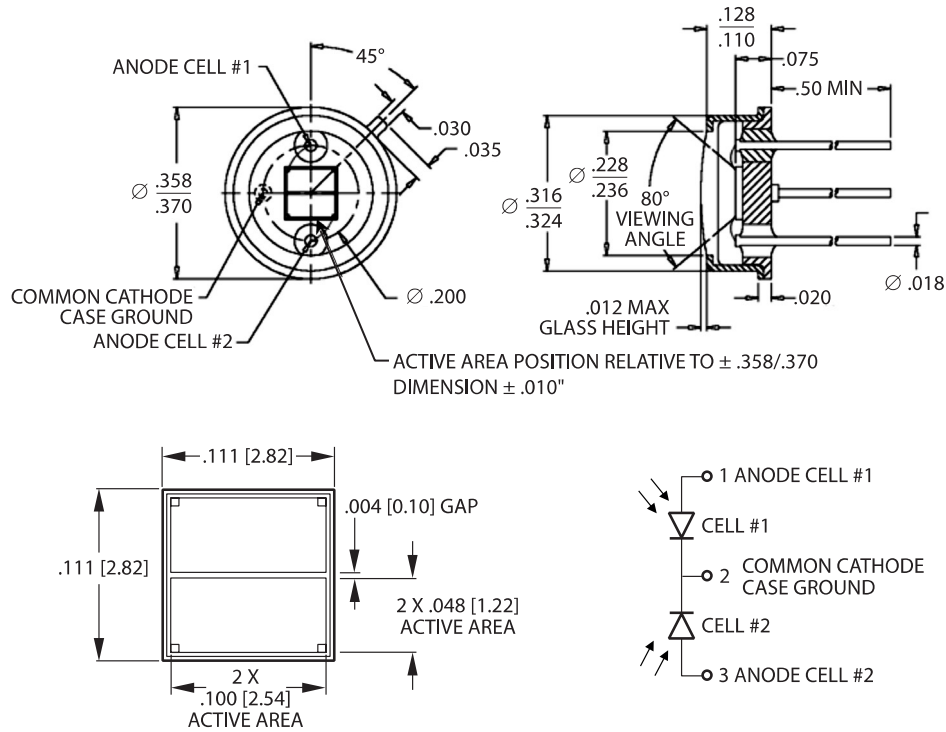

Dimensions are in inch [metric] units.

Specifications are subject to change without prior notice.