

AFBR-S4N66P024M

2×1 NUV-MT Silicon Photomultiplier Array

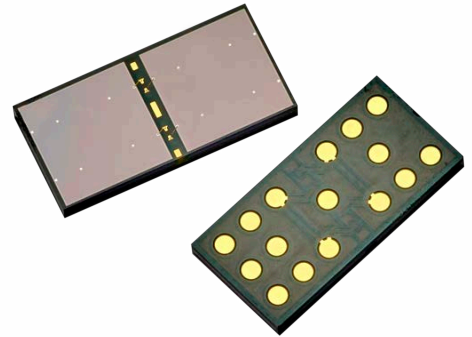

Description

The Broadcom® AFBR-S4N66P024M is a Silicon Photomultiplier (SiPM) array used for ultra-sensitive precision measurements of single photons. Two 6 mm × 6 mm SiPMs are arranged in a 2×1 element array with a pitch of 7 mm. Larger areas can be covered with a SiPM-pitch of 7 mm by tiling multiple AFBR-S4N66P024M arrays. The passivation layer is a clear epoxy mold compound (EMC) highly transparent down to UV wavelengths. This results in a broad response in the visible light spectrum with high sensitivity towards blue and near-UV region of the light spectrum. The array is best suited for the detection of low-level pulsed light sources, especially for detection of Cherenkov or scintillation light from the most common organic (plastic) and inorganic scintillator materials (for example, LSO, LYSO, BGO, NaI, CsI, BaF, LaBr). This product is lead-free and RoHS compliant.

Block Diagram

Figure 1: AFBR-S4N66P024M Block Diagram of Single SiPM Element

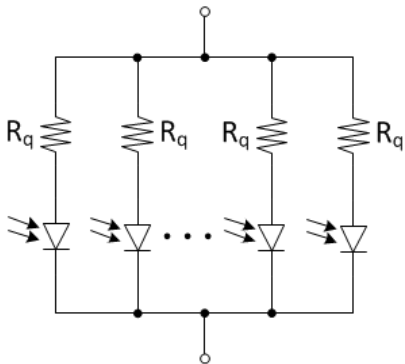

Features

- 2 × 1 SiPM array
- Array size: 13.54 mm × 6.54 mm
- High PDE (63% at 420 nm)
- Excellent SPTR and CRT
- Excellent uniformity of breakdown voltage
- Excellent uniformity of gain
- Four-side tilable, with high fill factors
- Cell pitch: 40 μm
- Highly transparent epoxy protection layer
- Operating temperature range from -20°C to +60°C
- RoHS, CFM, and REACH compliant

Applications

- X-ray and gamma-ray detection
- Gamma ray spectroscopy
- Safety and security
- Nuclear medicine
- Positron emission tomography
- Life sciences
- Flow cytometry
- Fluorescence - luminescence measurements
- Time-correlated single photon counting
- High energy physics
- Astrophysics

Mechanical Drawing and Pin Layout

Figure 2: Package Drawing with Dimensions

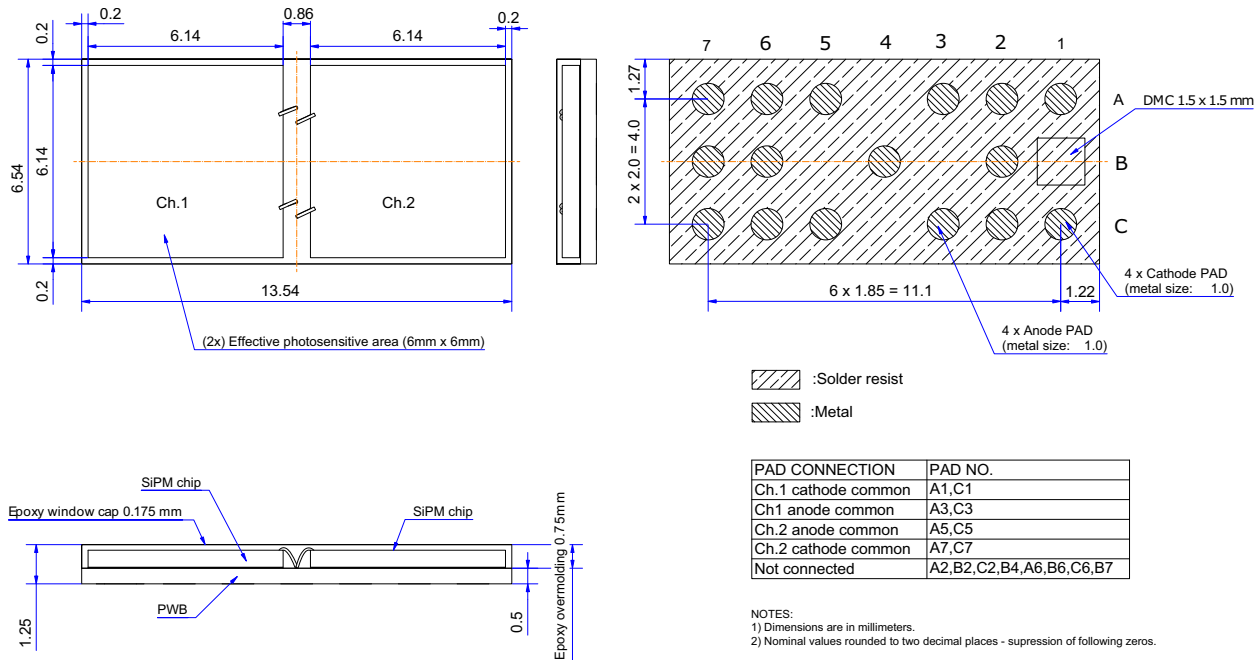
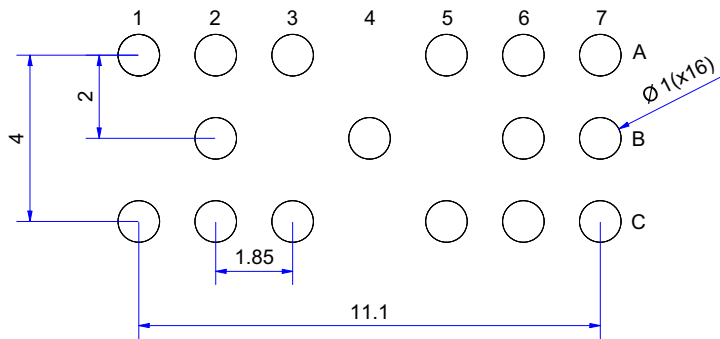

Figure 3: Recommended Landing Pattern Diagram



Note: Dimensions are in millimeters.

Reflow Soldering Diagram

Figure 4: Recommended Reflow Soldering Profile

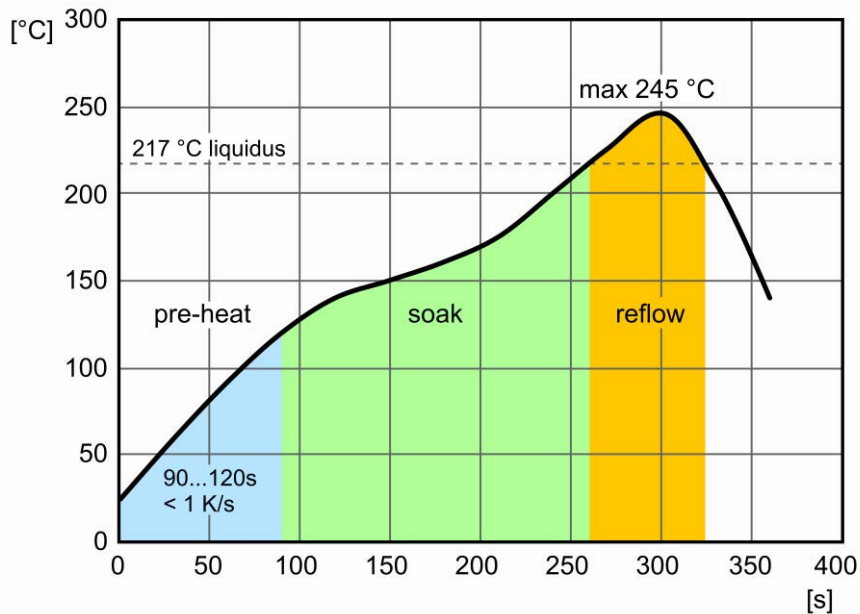

Absolute Maximum Ratings

Stresses in excess of the absolute maximum ratings can cause damage to the devices. Limits apply to each parameter in isolation. Absolute maximum ratings are those values beyond which damage to the device may occur if these limits are exceeded for other than a short period of time.

Parameter	Symbol	Min.	Max.	Units
Storage Temperature	T_{STG}	-20	+60	°C
Operating Temperature ^a	T_A	-20	+60	°C
Soldering Temperature ^{b, c}	T_{SOLD}	—	245	°C
Lead Soldering Time ^{b, c}	t_{SOLD}	—	60	s
Electrostatic Discharge Voltage Capability (HBM)	ESD_{HBM}	—	2	kV
Electrostatic Discharge Voltage Capability (CDM)	ESD_{CDM}	—	500	V
Operating Overvoltage	V_{OV}	—	16	V

a. Biased at constant voltage = 12V above breakdown.

b. The AFBR-S4N66P024M is reflow-solderable according to solder diagram as shown in [Figure 4](#).

c. The moisture level definition (MLD) is according to MSL 5. The floor life is 48 hours at 30°C and 60% relative humidity. No baking is required before soldering unless the floor life is exceeded. For more details on soldering and handling, refer to the Broadcom *AFBR-S4NxxPyy4M: NUV-MT Handling and Soldering* application note (AFBR-S4NxxPyy4M-AN).

Device Identification

Each device can be identified and tracked by a unique data matrix code (DMC) on the back of the PCB. The code is structured as follows: YYWWNNNNNN (Y – year, W – week, N – running number). An example DMC is shown in [Figure 5](#).

Figure 5: Example Data Matrix Code for Device Identification



Device Specification

Features measured at 25°C unless otherwise specified.

Geometric Features

Parameter	Symbol	Value	Units
Device Area	DA	13.54 × 6.54	mm ²
Total Active Area	AA	6 × 6 × 2	mm ²
Element Active Area	EAA	6 × 6	mm ²
Micro Cell Pitch	L _{cell}	40	μm
Number of Micro Cells per Element	N _{cells}	22428	—

Optical and Electrical Features

Values are measured at 12V above breakdown.

Parameter	Symbol	Min.	Typ. ^a	Max.	Units	Reference Plots
Spectral Range	λ	250	—	900	nm	Figure 6
Peak Sensitivity Wavelength	λ_{PK}	—	420	—	nm	Figure 6
Photo-Detection Efficiency	PDE at λ_{PK}	—	63	—	%	Figure 7
Dark Current per Element	I_D	—	8.6	—	μA	Figure 8
Dark Count Rate per Unit Area ^b	DCR/mm ²	—	125	—	kcps	Figure 9
Dark Count Rate per Element	DCR	—	4.4	—	Mcps	Figure 9
Gain	G	—	7.3	—	$\times 10^6$	Figure 10
Optical Crosstalk ^c	P_{Xtalk}	—	23	—	%	Figure 11
Afterpulsing Probability	P_{AP}	—	< 1	—	%	—
Recharge Time Constant	τ_{fall}	—	55	—	ns	Figure 12
Breakdown Voltage	V_{BD}	—	32.5	—	V	Figure 8
Nominal Terminal Capacitance per Element ^d	C_T	—	1550	—	pF	—
Temperature Coefficient of Breakdown voltage (23...27°C)	$\Delta V_{BR}/\Delta T$	—	30	—	mV/°C	—
Temperature Coefficient of Gain (23...27°C) ^e	$\Delta G/\Delta T$	—	1.46	—	$\times 10^4/^\circ C$	—

- Typical values are measured at 12V above breakdown
- Measured at 0.5 p.e. amplitude. Measurement does not include delayed correlated events.
- Calculated as the sum of direct, delayed crosstalk, and after-pulsing probabilities.
- Measured at 40V using input sine wave with $f = 200$ kHz and $V_{in} = 500$ mV.
- Calculated from gain dependence on V and breakdown voltage temperature coefficient: $\Delta G/\Delta T = \Delta G/\Delta V \times \Delta V_{BR}/\Delta T$.

Reference Plots

Typical features measured at 25°C unless otherwise specified.

Figure 6: PDE vs. Wavelength

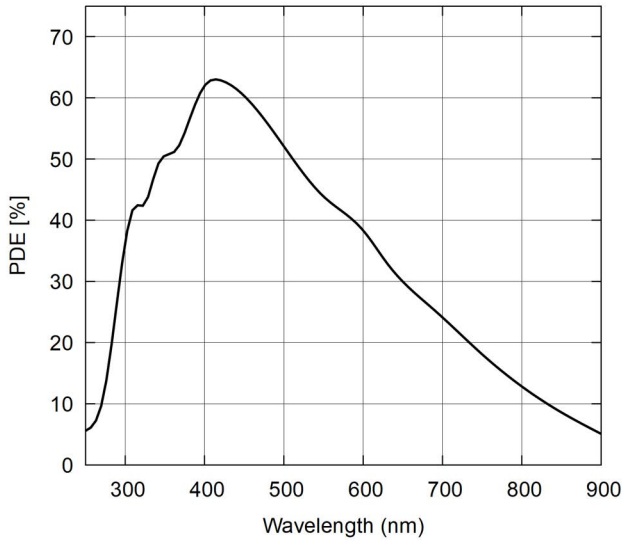

Figure 7: PDE vs. OV at 420 nm

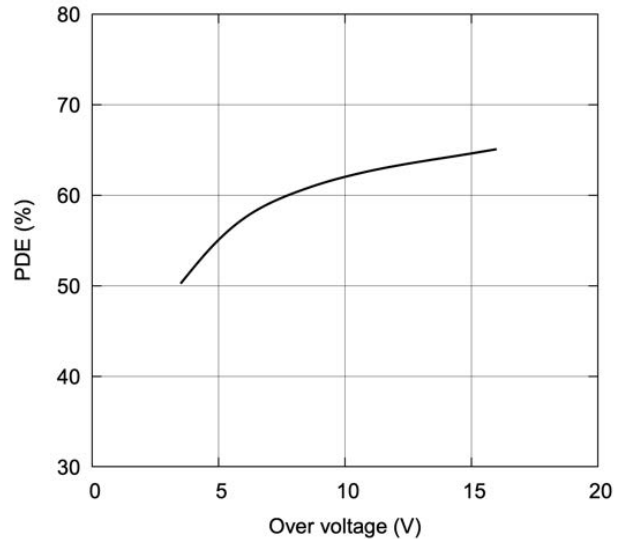

Figure 8: Reverse IV Curve in Dark Conditions

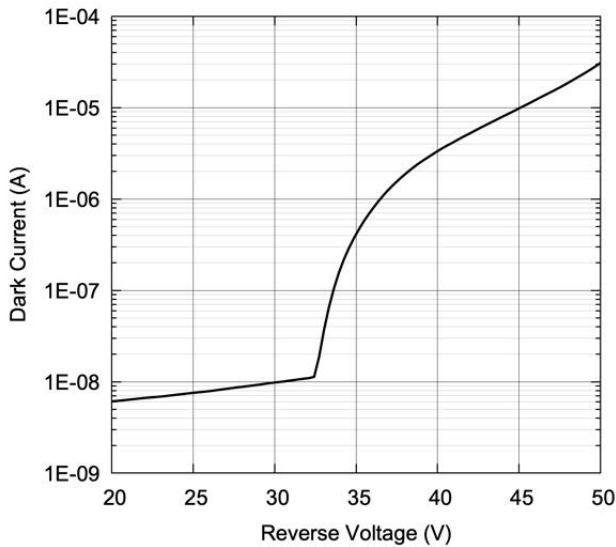

Figure 9: Dark Count Rate vs. Overvoltage

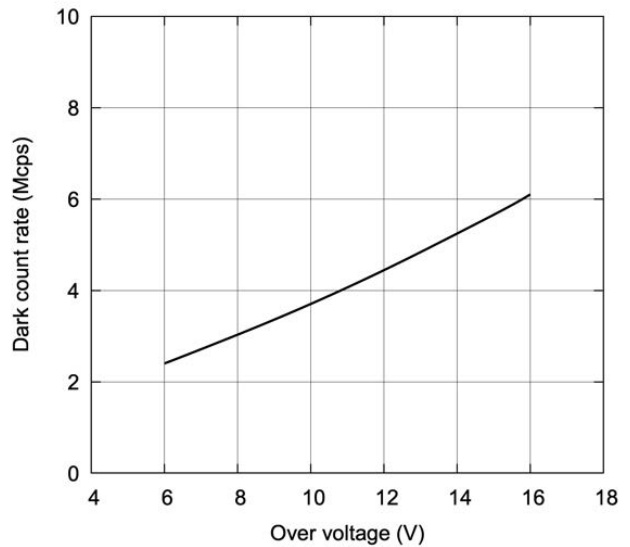

Figure 10: Gain vs. Overvoltage

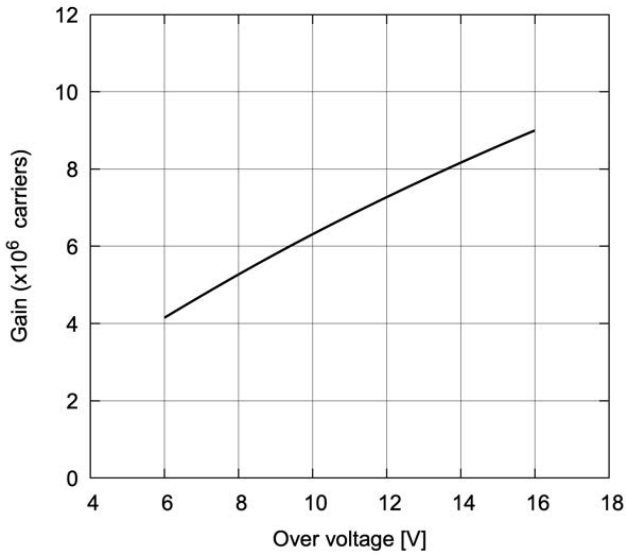

Figure 11: Total Correlated Noise vs. Overvoltage

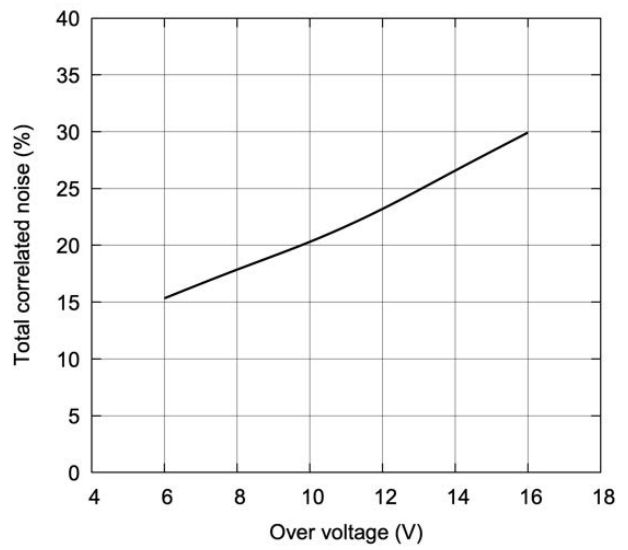
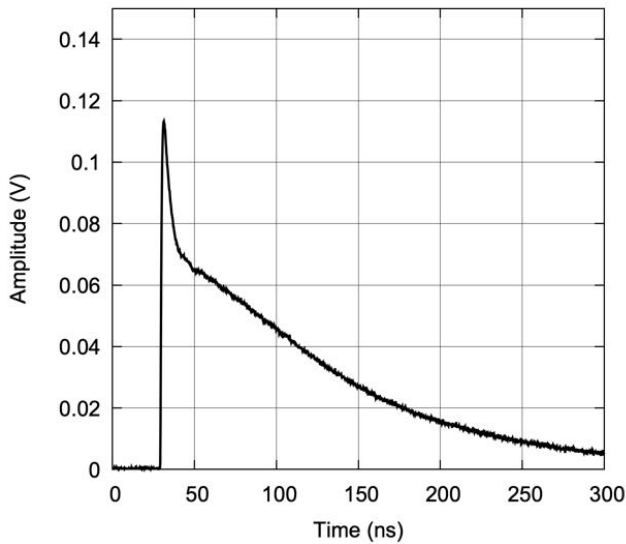

Figure 12: Typical Pulse Waveform in Response of a Picosecond Laser-Pulse on a Load Impedance of 25Ω and Applied Bias of 12V above Breakdown



Copyright © 2021–2025 Broadcom. All Rights Reserved. The term “Broadcom” refers to Broadcom Inc. and/or its subsidiaries. For more information, go to www.broadcom.com. All trademarks, trade names, service marks, and logos referenced herein belong to their respective companies.

Broadcom reserves the right to make changes without further notice to any products or data herein to improve reliability, function, or design. Information furnished by Broadcom is believed to be accurate and reliable. However, Broadcom does not assume any liability arising out of the application or use of this information, nor the application or use of any product or circuit described herein, neither does it convey any license under its patent rights nor the rights of others.

